

AMS MU800 Hi Curtain Wall system

MU800Hi mullion drained curtain walling system offers unique architectural design features combined with market leading performance. The system is propriety based and is suitable for both low & high rise applications. MU800Hi offers a 55mm sight line and comes in a suite of mullion / transom combinations which range from 60, 96, 125, 145, 155 and 200 mm in depth. The range of thermal isolators allow for glazing with 28, 32, 36, 40 and 54mm units. MU800 Hi offers an extensive range of capping options including fin, squared, boxed and curved profiles. It offers a modular design with the use of our Matrix cap sections. The matrix cap system is available in 3 different depths to suit a range of interface details and also has the option of a frameless sash insert.

Thermal Performance

AMS MU800Hi curtain walling is designed to offer the specifier excellent U-frame and U-curtain wall values. This is achieved with the use of the extended thermal isolator which greatly reduces the energy loss across the façade and improves the CO2 footprint of the building. Building thermal performance requirements are easily achieved with the use of the AMS MU800Hi curtain wall system. Thermal performance of curtain walls to be calculated in accordance with BS EN ISO 12631:2012.

Scope

This specification defines materials, fabrication, paint finishes, and size limitations for curtain walling.

Materials

Aluminium profiles are extruded from aluminium alloy 6063 T6 complying with BS EN 12020-2:2008 and BS EN 755: 1 – 9.

Paint Finishes

Polyester Powder Coatings

Aluminium profiles are polyurethane powder coated to BS EN 12206-1:2004. AMS offers in house painting with the following Qualicoat approved paint suppliers –Valspar / Syntha Puvin, Akzo-Nobel Interpon, Axalta.

Decoral

Aluminium profiles can be polyurethane powder coated with a woodgrain effect paint finish to BS EN 12206-1:2004. Woodgrain finishes include :

Chestnut, Cinnamon, Dark Oak, Finest Black, Golden Oak, Knotted Pine, Mahogany, Natural Maple, Natural Oak, Natural Oregon, Oregon, Raw Teak, Rosewood, Teak, Wengen Walnut, Mandal Maple, Winchester Oak, Worn Ash, Burnt Oak, Barn Oak, Truffle Oak, Mid Oak and Teak Softwood

Anodised

Aluminium profiles can be anodised to BS EN ISO 7599:2010 or BS 3987:1991.

Fabrication

The AMS MU800 Hi curtain walling system is designed as a stick system and frame members such as mullions and transoms shall be fabricated in accordance with AMS technical literature and transported to site as prepared components. The stick grid system shall be assembled on the proposed facade area as per fabrication shop drawings and engineering calculations.

Mullions shall be square cut and can be joined with specially designed jointing sleeves. Mullions shall run the full height of the façade with transoms spanning in between. Transoms shall be notched and lapped over the mullion and a special sealing gasket is to be positioned between mullions and transoms for improved weather and air tightness. Mullion splice joints are sealed and weathered using splice cover profiles. Transoms to be screw fixed into the position with No.8 x 19 tamper proof screws.

Fixing points should be advised by a structural engineer and relevant fixing brackets approved so that all loads are transferred back to the main building structure. Low modulus silicone shall be used throughout for weathering joints as recommended by the silicone manufacturer.

Glazing

Glass shall be set against extruded gaskets internally which are fitted into gasket grooves in the mullions and transoms. Glass loading plates to be fitted to the screw port of the transom, each plate is to be in 150mm approximately from each end. Suitable PVC/EPDM glass support pieces are to be fitted between the glass and the loading plate. Material and size of the glass support piece should be as per the glass manufacturer's recommendations. All Gaskets are EPDM and manufactured to BS 4255 and tested to BS EN 12365-4:2003. MU800 Hi can accommodate glazing thickness of 28, 32, 36, 40 and 54 mm. Glazing shall be in accordance with current standards and Building Regulations.

Installation

AMS offer detailed installation instructions on all systems and these should be followed as per AMS's technical department's recommendations

Performance

Tested to CWCT standard for systemised building envelopes, test sequence B .

Air Classification – Class 4: 600 Pa.

Water Tightness – Class R7: 600 Pa.

Wind Resistance – Class EA2400.

Wind resistance safety – Class - 3600Pa.

Impact resistance - BS EN 14019:2016.

Soft body - Serviceability, class E2.

Safety, class E4 & E5.

Hard body - Serviceability, class E5.

Safety, class E5.

CWCT TN75 / TN 76

Soft body - Serviceability, category B,C, E&F - Class E1.

Safety, category B,C, E&F - Class - Negligible risk.

Hard body - Serviceability, category B&C - Class 1.

Safety, category B&C - Class - Negligible risk.

Structure

Section performance requirements must be calculated from site conditions and all loading requirements. All structural profiles shall be designed so as the maximum deflection of any member shall not exceed the limits as set out by the CWCT standard for systemised building envelopes, Part 3. Further advice on deflection limitations should be sought from the glass supplier.

CWCT Guidelines for deflection:

Length	Allowable deflection
$H \leq 3000$	$\Delta \leq H/200$
$3000 < H < 7500$	$\Delta \leq 5 + H/300$
$7500 \leq H$	$\Delta \leq H/250$

The recommended torque setting for the pressure plate screw is 5.5 - 6.5 Nm. Where glass weights are in excess of 100Kg's and/or the transom spans more than 2.5m, transom support blocks are to be fitted to the mullion. Maximum allowable weight of glass unit with support block is 510kg's (With 3 no. 14 x 19mm S/S pan head screws & MU799 transom). For large units ensure the transom is within deflection limits. Standard glass support plates are supplied in 100mm cut pieces, for unit above 300 kgs increase glass support plates to 150mm.

Insert opening vents and doors

Details and specification information for these insert products can be found in the window and door section of AMS's technical literature.

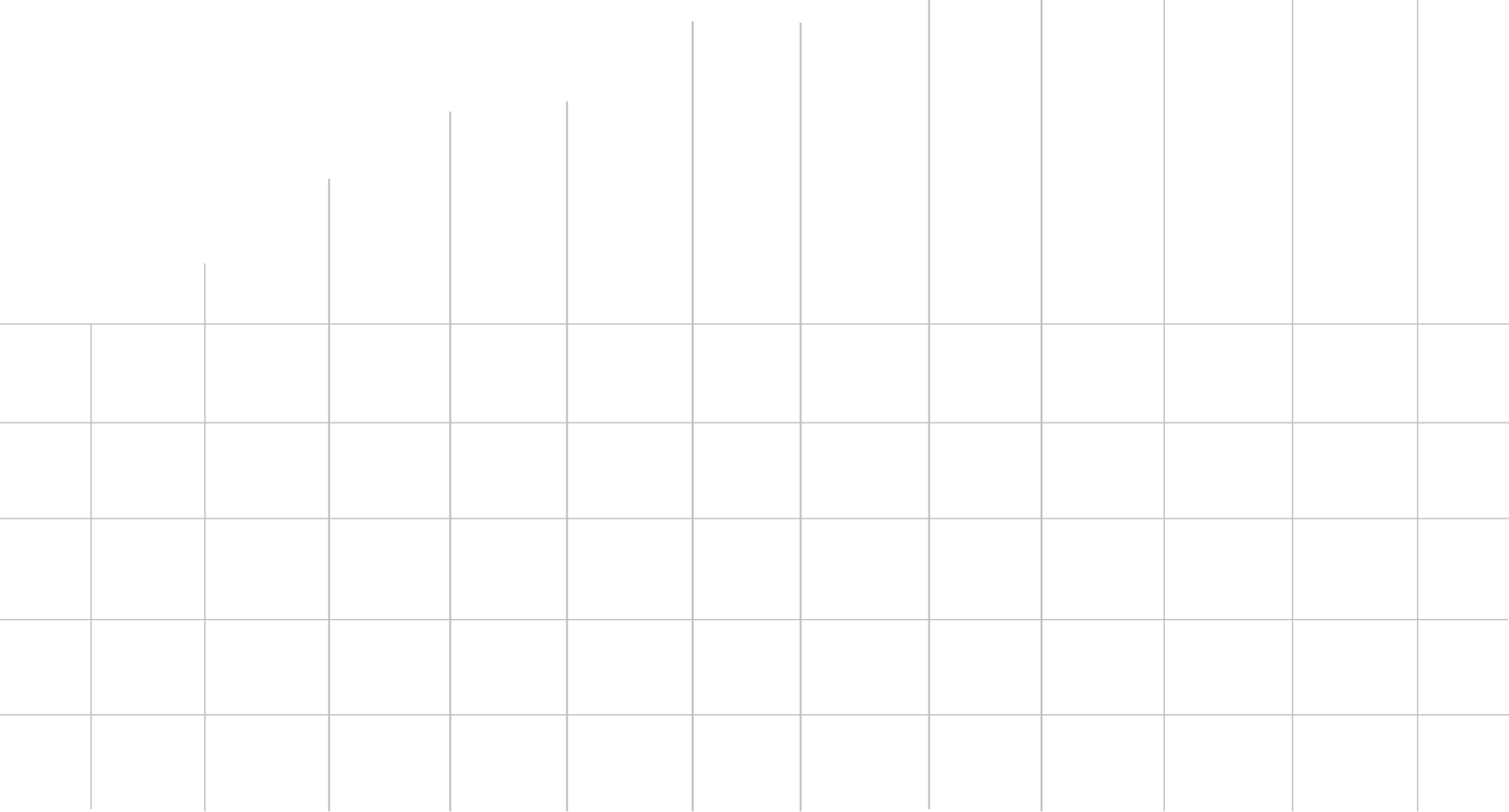

- 1.4.01 : Mullions & Transoms
- 1.4.02 : Mullions & Transoms
- 1.4.03 : Cappings & Pressure plates
- 1.4.04 : Inserts
- 1.4.05 : Gaskets & Accessories
- 1.4.06 : Accessories
- 1.4.07 : Sleeved Mullions
- 1.4.08 : Profile assembly
- 1.4.09 : Capping assembly
- 1.4.10 : Mullion / Transom glass assembly
- 1.4.11 : Mullion / Transom glass assembly
- 1.4.12 : Typical head detail
- 1.4.13 : Typical head detail with Kingspan cladding
- 1.4.14 : Typical cill detail
- 1.4.15 : Typical fixing detail - Splice joint
- 1.4.16 : Typical fixing detail - Splice detail
- 1.4.17 : Sash insert details
- 1.4.18 : Door insert details
- 1.4.19 : Typical jamb details
- 1.4.20 : Typical door jamb details
- 1.4.21 : Corner assemblies
- 1.4.22 : Typical head detail - sloped glazing
- 1.4.23 : Typical eaves detail
- 1.4.24 : Typical ridge details
- 1.4.25 : Typical cill details - sloped glazing
- 1.4.26 : False Mullion / Transom detail
- 1.4.27 : Mullion - Matrix capping details
- 1.4.28 : Transom - Matrix capping details
- 1.4.29 : Matrix capping details
- 1.4.30 : Matrix capping details
- 1.4.31 : Matrix capping details
- 1.4.32 : Facetted Curtain Wall

AMS Ltd. Wallingstown, Little Island, Co. Cork:

Tel: 021 4705100 **Fax:** 021 4705198, **E-mail:** pohara@ams.ie, **Web:** www.ams.ie



MU 800Hi - CAPPED CURTAIN WALL SYSTEM

Mullions and Transoms

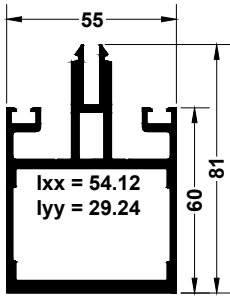

MU 792
MULLION
Sleeved
lxx = 69.1
lyy = 45.0

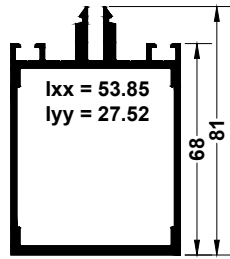

MU 783
TRANSOM

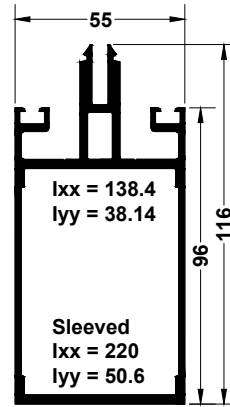

MU 795
MULLION
Sleeved
lxx = 220
lyy = 50.6

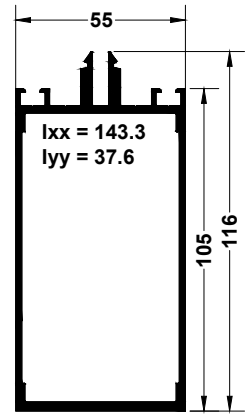

MU 796
TRANSOM

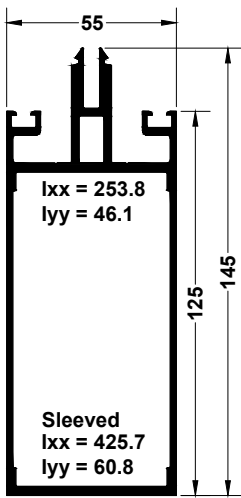

MU 782
MULLION
Sleeved
lxx = 425.7
lyy = 60.8

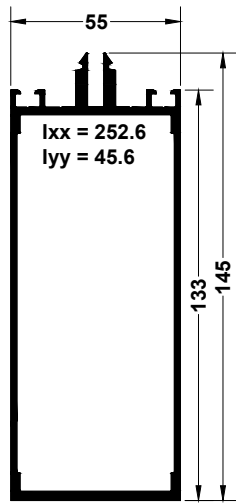

MU 794
TRANSOM

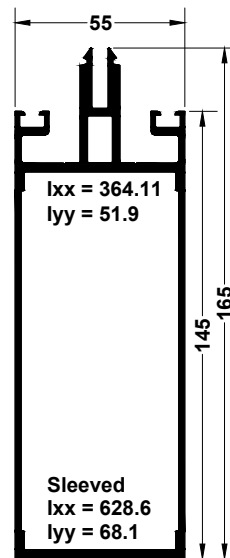

MU 798
MULLION
Sleeved
lxx = 628.6
lyy = 68.1

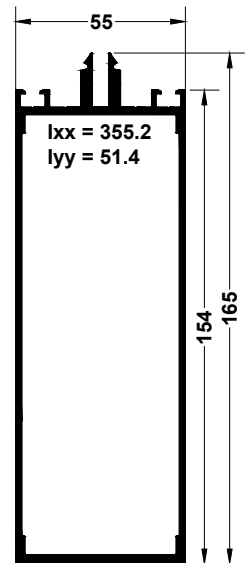

MU 799
TRANSOM

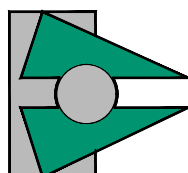

MU 800Hi - CAPPED CURTAIN WALL SYSTEM

Mullions and Transoms

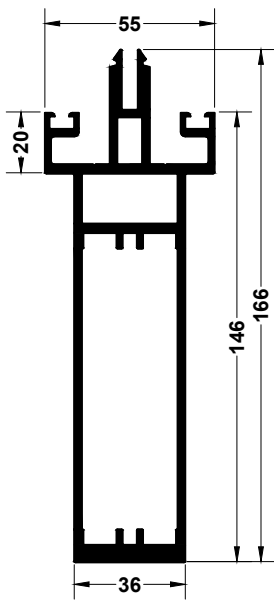

**MU 778
SLIM MULLION**
Ixx = 397.9
Iyy = 31.7

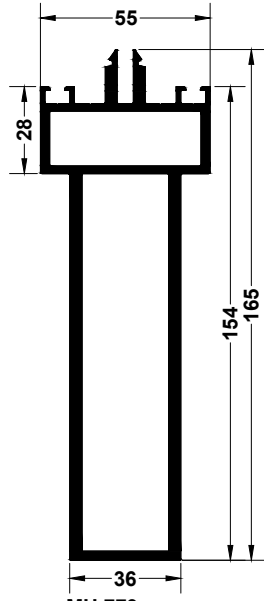

**MU 779
SLIM TRANSOM**
Ixx = 417.7
Iyy = 42.7

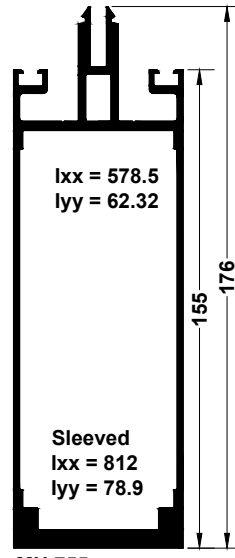

**MU 755
MULLION**

Ixx = 578.5
Iyy = 62.32

Sleeved
Ixx = 812
Iyy = 78.9

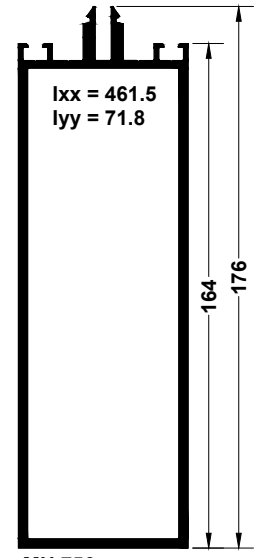

**MU 756
TRANSOM**

Ixx = 461.5
Iyy = 71.8

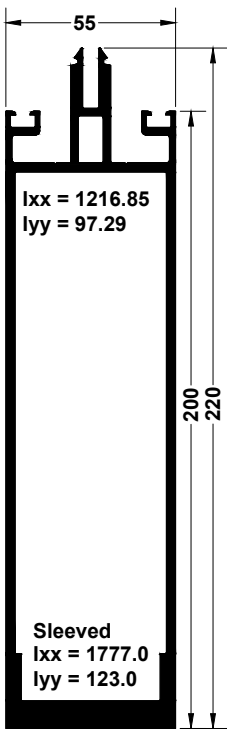

**MU747
MULLION**

Ixx = 1216.85
Iyy = 97.29

Sleeved
Ixx = 1777.0
Iyy = 123.0

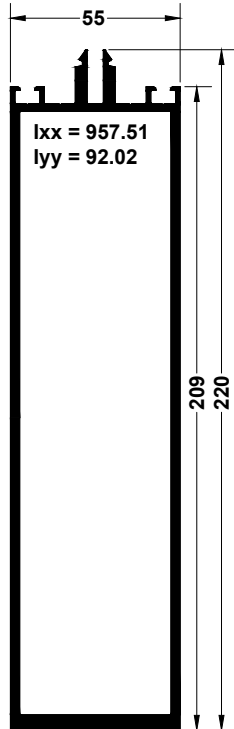

**MU748
TRANSOM**

Ixx = 957.51
Iyy = 92.02

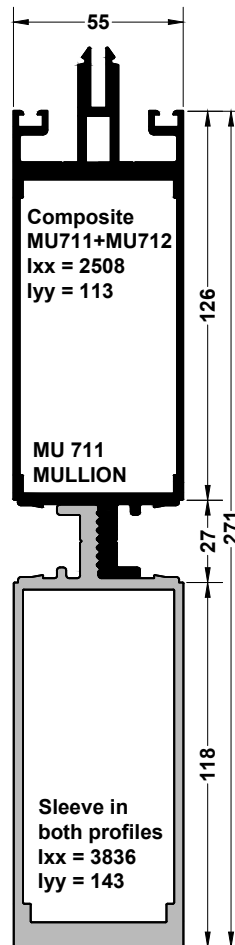

**MU 712
MULLION**

**MU 713
CLOSER**

Composite
MU711+MU712
Ixx = 2508
Iyy = 113

Sleeve in
both profiles
Ixx = 3836
Iyy = 143

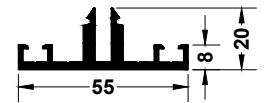

**MU793
TRANSOM**

For composite mullion
limitations see page 1.4.07

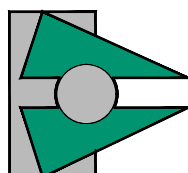

MU 800Hi - CAPPED CURTAIN WALL SYSTEM

Cappings and Pressure Plates

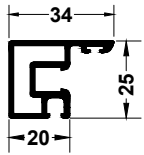

MUSL 01
'Matrix' Capping

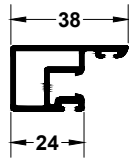

MUSL 05
'Matrix' Capping

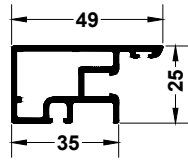

MUSL 04
Extended 'Matrix' Capping

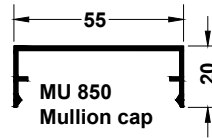

MU 850
Mullion cap

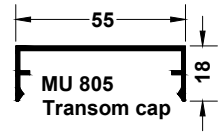

MU 805
Transom cap

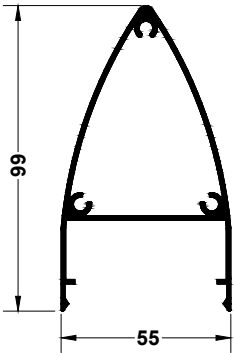

MU889
Bullet cover cap
with screw ports

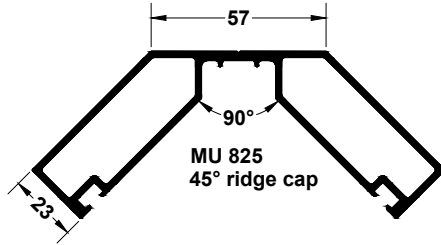

MU 825
45° ridge cap

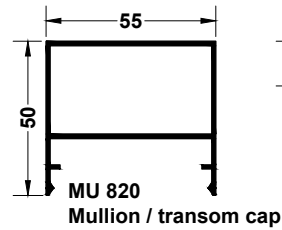

MU 820
Mullion / transom cap

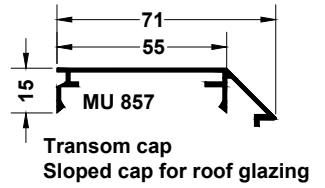

MU 857
Transom cap
Sloped cap for roof glazing

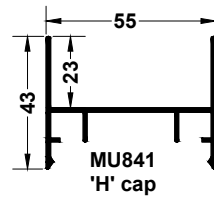

MU841
'H' cap

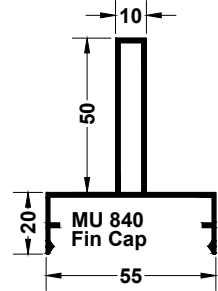

MU 840
Fin Cap

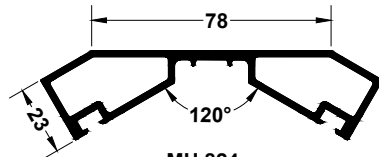

MU 824
30° ridge cap

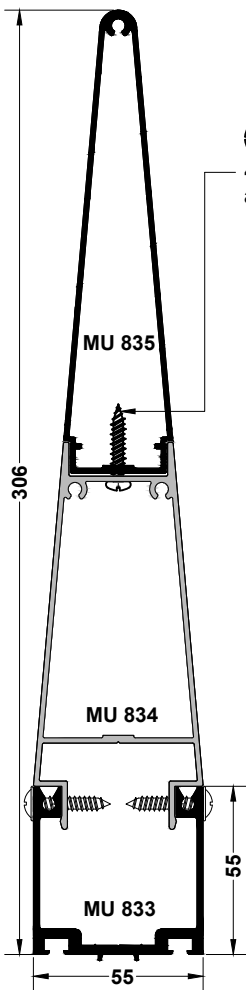

Wing Cap

4.8 x 19 pan pozi screw
at 1.5m c/c.

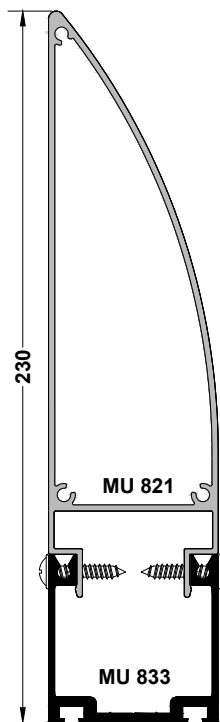

Radius Cap

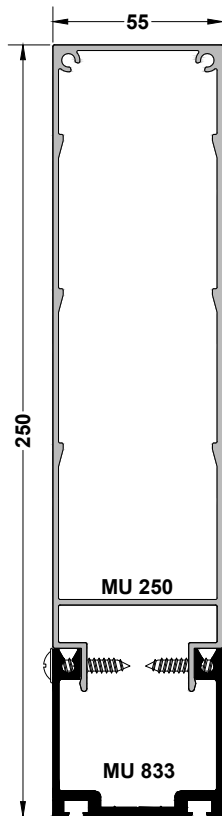

Box Cap

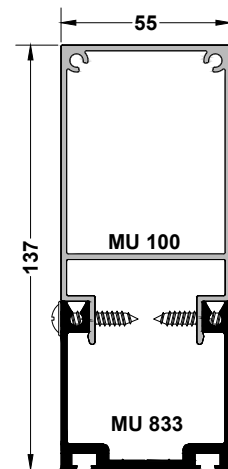

MU 100 Cap

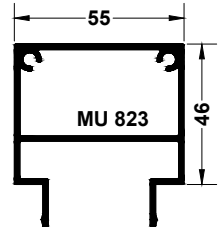

MU 822

MU 823

4.8 x 25
flange screw

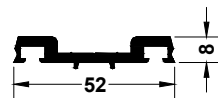

MU847
Pressure plate

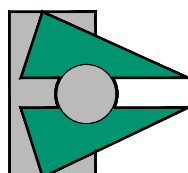

MU 800Hi - CAPPED CURTAIN WALL SYSTEM

Inserts

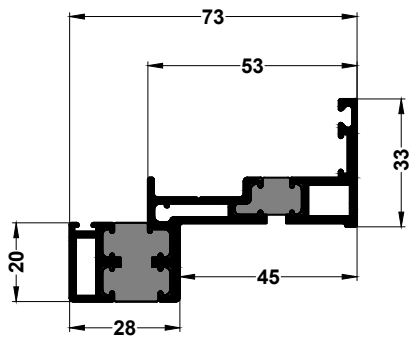

MUSL07
Matrix frame - 28mm glazing

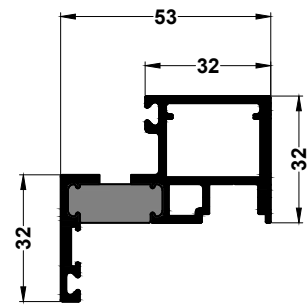

MUSL 06
Matrix sash

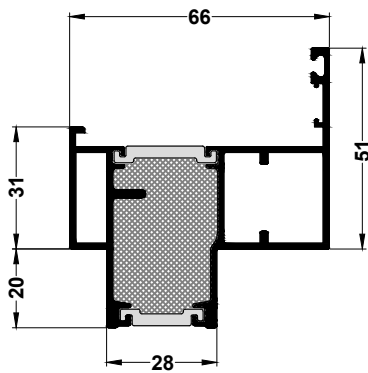

XT6 209
Insert for 28mm glazing

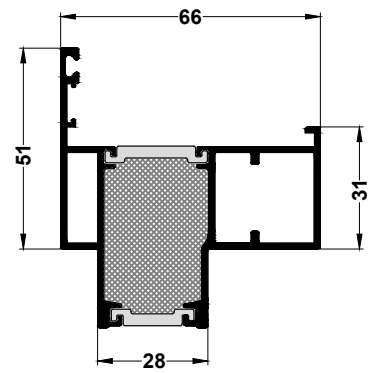

XT6 210
Insert for 28mm glazing,
tilt and turn / door frame

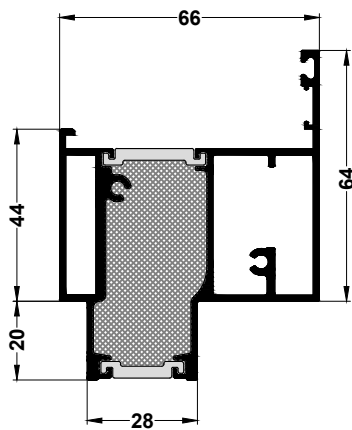

XT6 211
Insert for open out doors

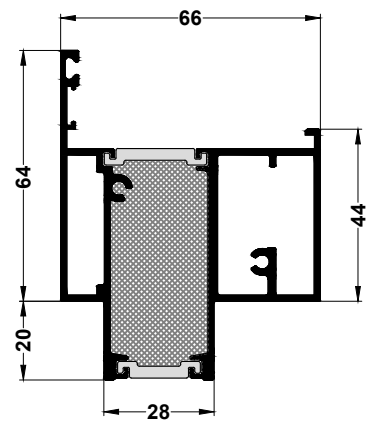

XT6 212
Insert for open in doors

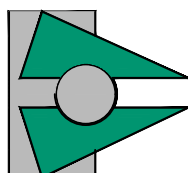

MU 800Hi - CAPPED CURTAIN WALL SYSTEM

Gaskets and Accessories



CWG001
Pressure plate gasket



CWG 010
Transom gasket



CWG 014
Mullion gasket

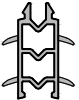

CWATB2
Isolator for 28mm units



CWATB
Isolator for 40mm Units
(Used with conjunction with CWATB2)



CWATB 32
Add on for 32mm glazing



CWATB 36
Add on for 36mm glazing



G1550
Transom sealing / end gasket.

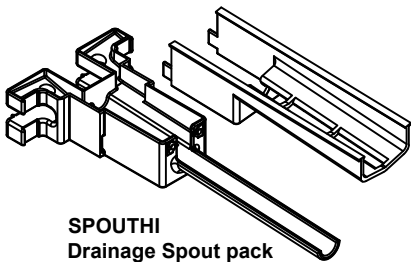

SPOUTHI
Drainage Spout pack
(Spout + Addon)

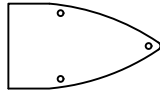

MU889E
End plate for MU899 capping



MU821EC
End plate for *Radius* capping



MU250EC
End plate for *Box* capping

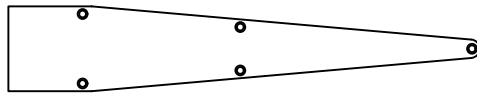

MU833E
End plate for *Wing* capping

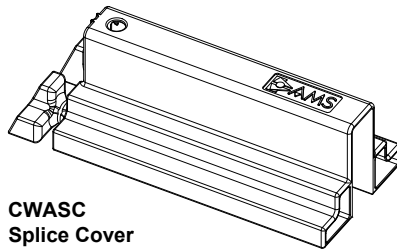

CWASC
Splice Cover

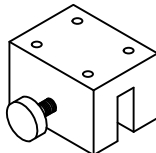

Mullion jig
T112

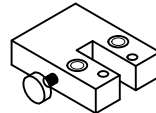

Transom jig
T113

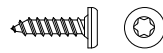

CWA030
No.8 x 19 tamper-proof
transom screw

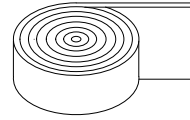

Butyl tape
50mm - CWG003



MUSLCLIP
Matrix Clip



(CDA016)
5.1 x 1200 Woolpile
for matrix cap MUSL05



4.8 x 450 Woolpile
for all matrix caps



8471
Matrix flipper gasket



Stepped drill bit
T114



CWA 031
Drill bit to suit
transom screw

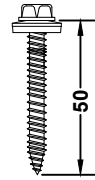

CWA050
No.14 x 50 hex head screw
with bonded washer
(28mm & 32mm glazing).

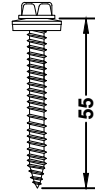

CWA055
No.14 x 55 hex head screw
with bonded washer
(36mm glazing)

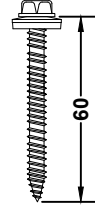

CWA060
No.14 x 60 hex head screw
with bonded washer
(40mm glazing).

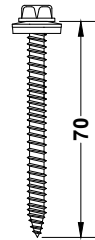

CWA070
No.14 x 70 hex head screw
with bonded washer
(54mm glazing).

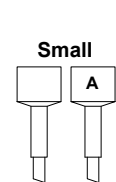

Transom drained
holes for cleats

Heads for punch tool

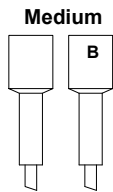

Mullion drained
holes for cleats

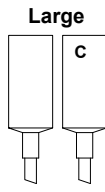

Mullion drained
holes for transom
fixing screws
(Oval head)

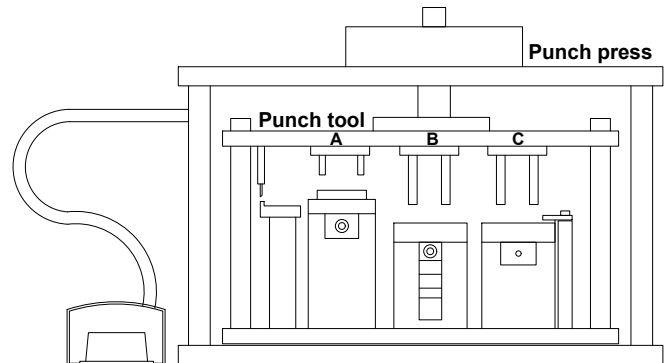

Punch press for curtain wall transoms

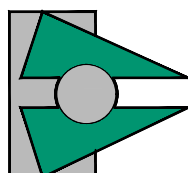

MU 800Hi - CAPPED CURTAIN WALL SYSTEM

Accessories

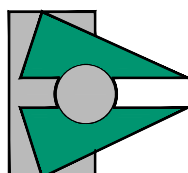
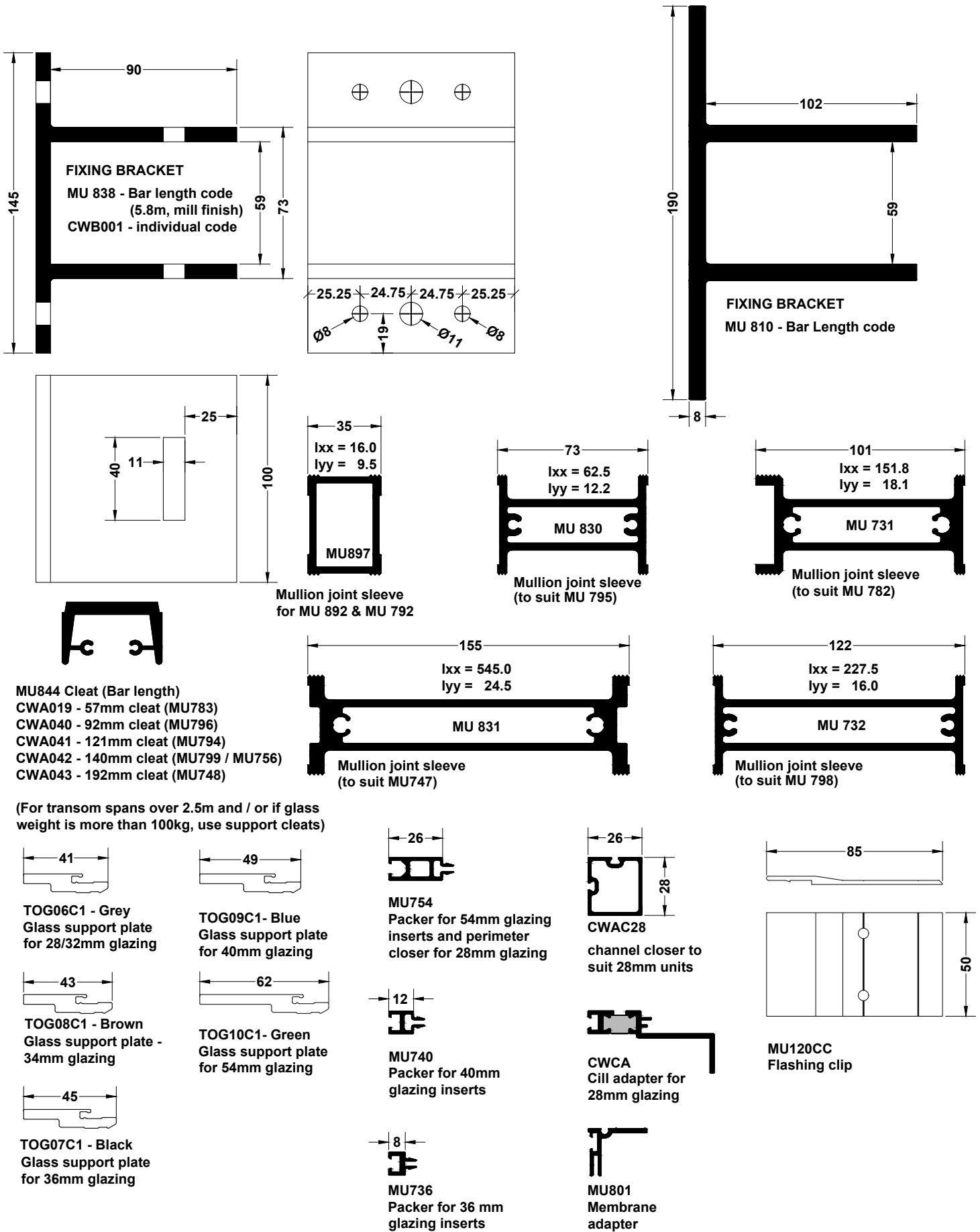

MU 800Hi - CAPPED CURTAIN WALL SYSTEM

Sleeved Mullions

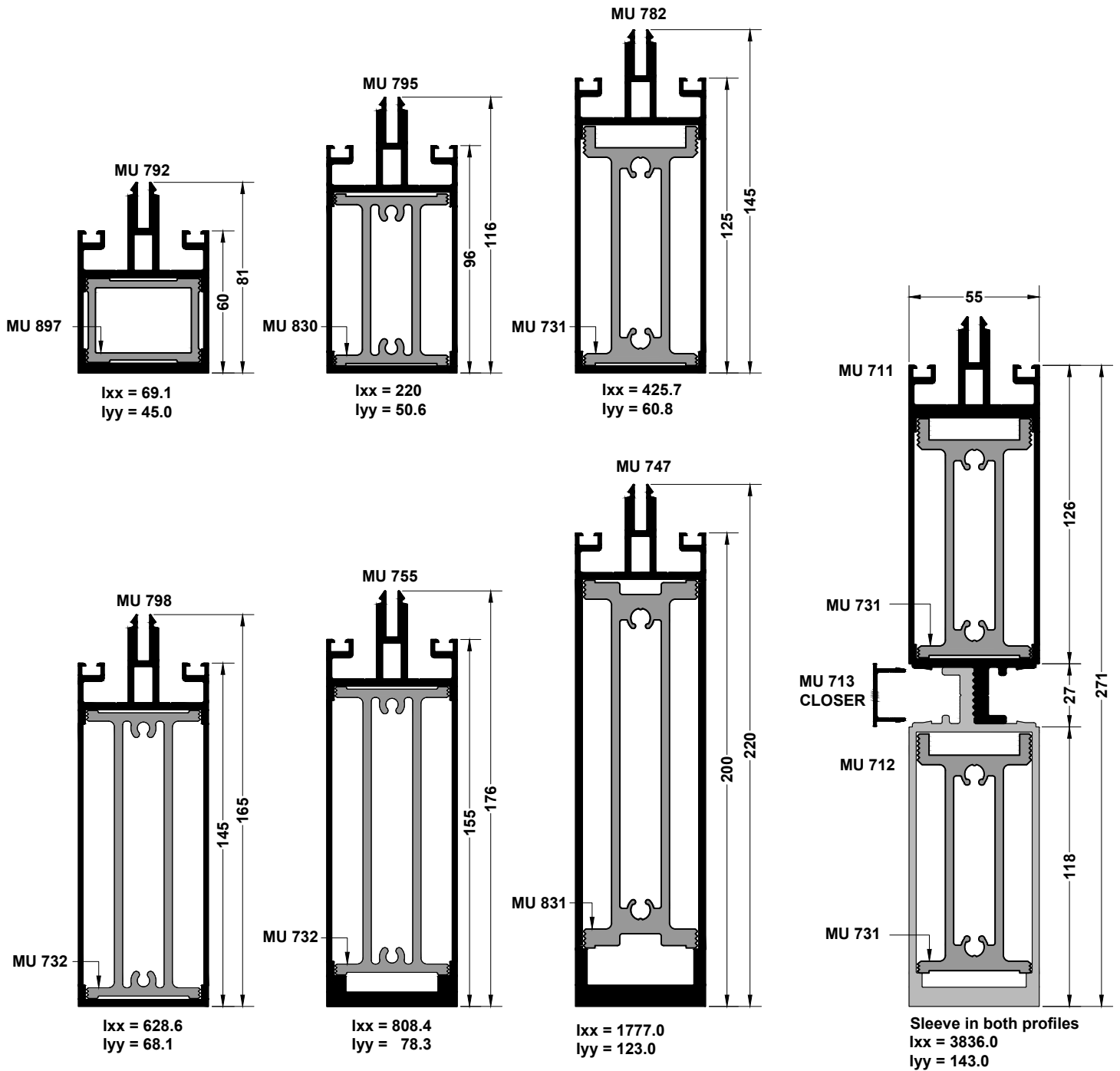

Composite mullion parameters are as follows:

Anything outside these parameters will require analysis by a certified structural engineer. For both options the mullion must be fully sleeved with MU 731 in both cavities, M10, socket head stainless steel bolts to be fitted at 250mm C/C and torque to 35Nm. (Fixing brackets at the head and cill have not been considered and should also be signed off by a certified engineer)

Span 1:

Mullion single height span = 6.590m

Mullion Centres = 1.2 m

Wind load = 1500 Pa.

Span 2:

Mullion single height span = 6.0m

Mullion Centres = 2.0m

Wind load = 1500 Pa.

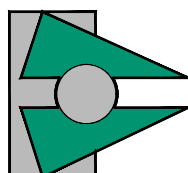

MU 800Hi - CAPPED CURTAIN WALL SYSTEM

Profile assembly

TRANSOM ASSEMBLY

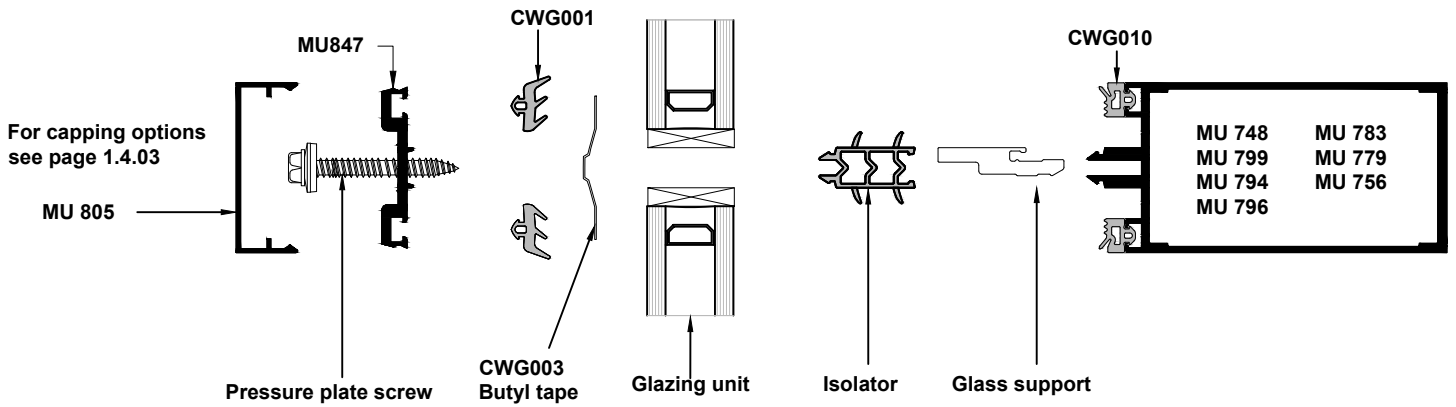

GLAZING THICKNESS	PRESS.PLATE SCREW	ISOLATOR	GLASS SUPPORT
28	CWA050	CWATB2	TOG06C1 - Grey
32	CWA050	CWATB2 + CWATB32	TOG06C1 - Grey
36	CWA055	CWATB2 + CWATB36	TOG07C1 - Black
40	CWA060	CWATB2 + CWATB	TOG09C1 - Blue
54	CWA070	CWATB2 + CWATB2	TOG10C1 - Green

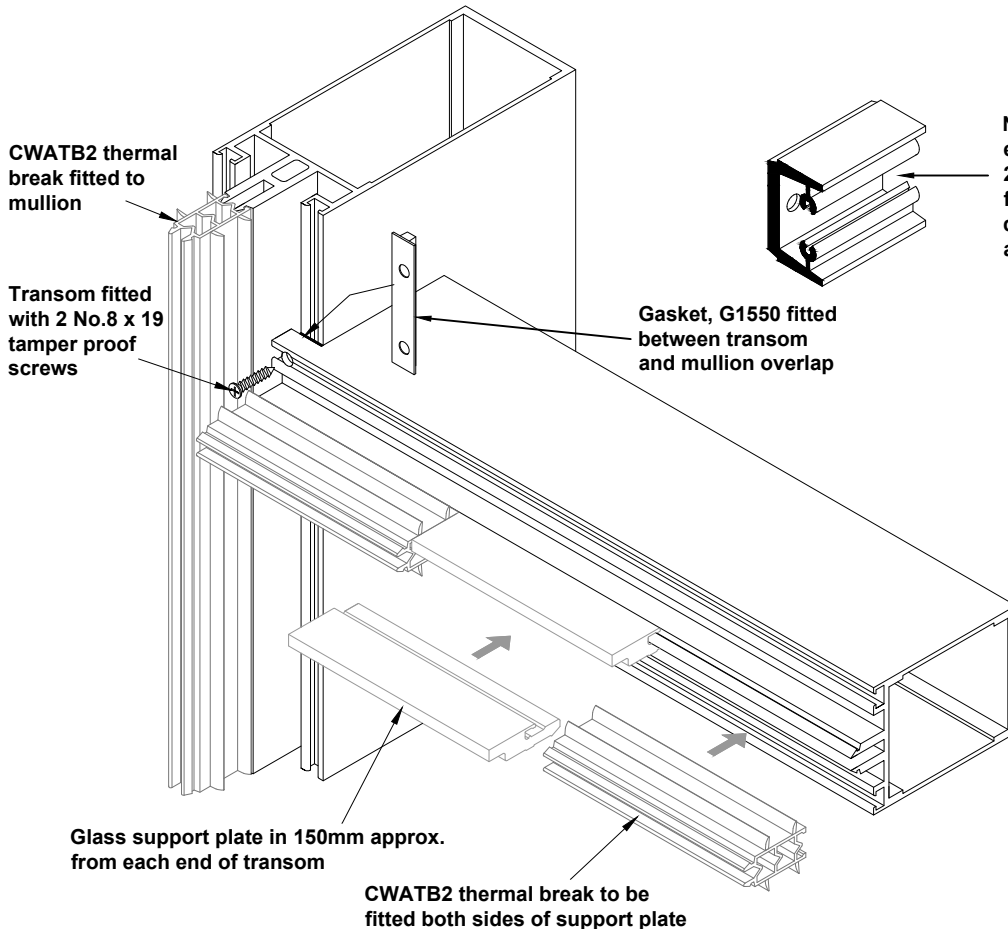
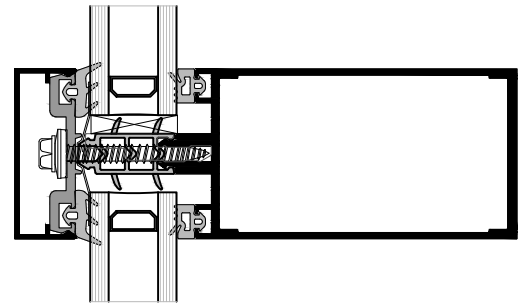

Note: Support cleat to be used when glazing unit exceeds 100 kg and / or transoms spans more than 2.5m. (See page 1.4.06 for cleat codes), Max load for transom / cleat combination is 500 kg. Ensure deflection on transom does not exceed 3mm as per CWCT guidelines.

Note:
Guide for glass area & glazing support plates:
2 No. Standard 100mm support plates (both in 150mm approx from each end) - max area of glass = 3.3m²

4 No. Standard 100mm support plates, 2 side by side positioned in 150mm approx from each end - max area of glass = 6.6m². Glass packers to be fitted for full width of both plates.

Glass packers:
Glazing packers to be fit for purpose, in accordance with the glass suppliers recommendations and also in accordance with BS 6262. At least 50% of the outer pane of glass to be supported by packers / support plates.

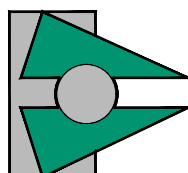

MU 800Hi - CAPPED CURTAIN WALL SYSTEM

Capping assembly

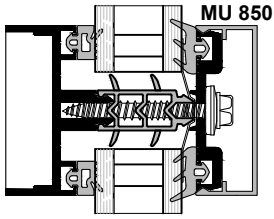

Standard capping

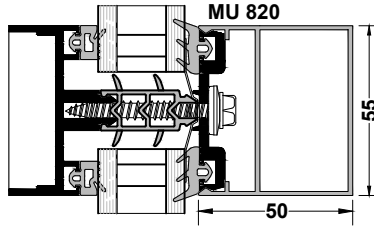

Standard capping

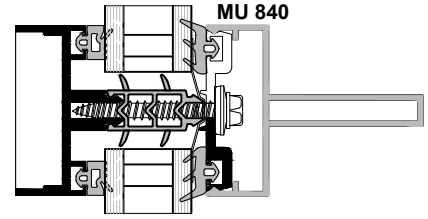

Fin capping

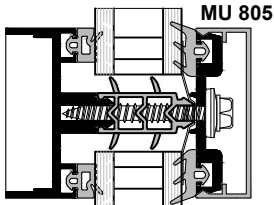

Standard capping

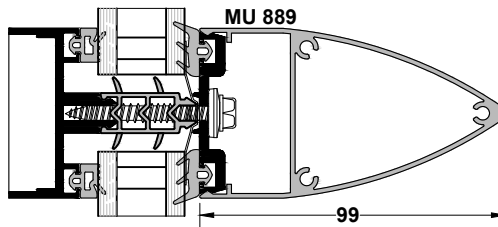

Bullet nose capping

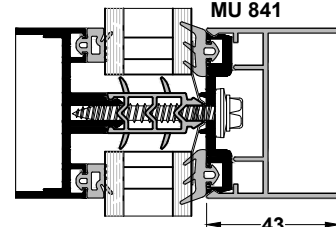

'H' Cap

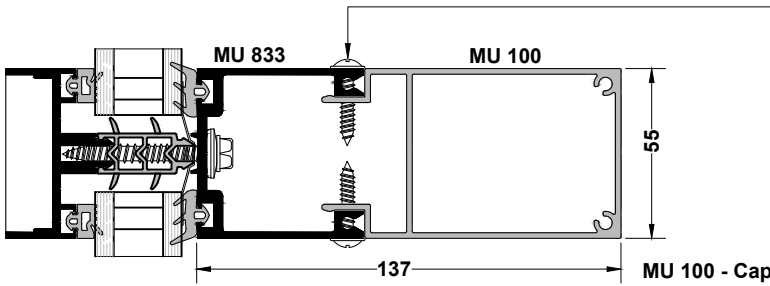

4.8 x 25
flange screw

Ø7mm hole drilled on a side wall of MU833. One 150mm up from the bottom and 150mm down from top, and at 1.0m c/c thereafter.

On caps over 4.0m, expansion should be considered and designed into the assembly.

Screws not to be overtightened in order to allow expansion in the assembly.

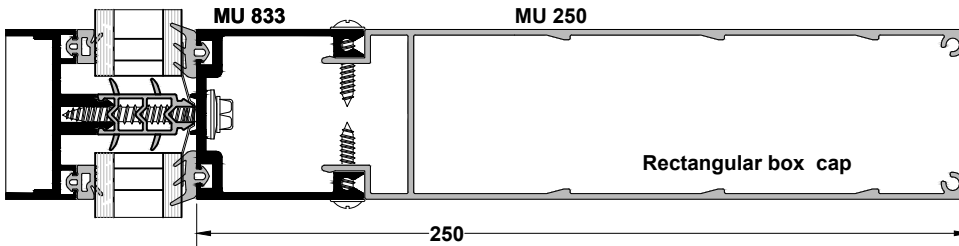

Rectangular box cap

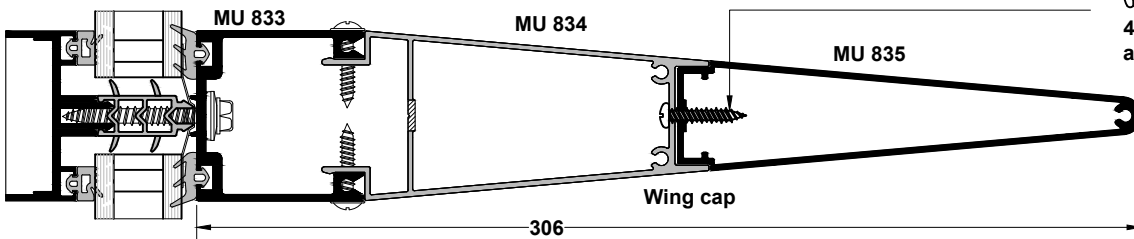

Wing cap

4.8 x 19 pan pozi screw
at 1.5m c/c.

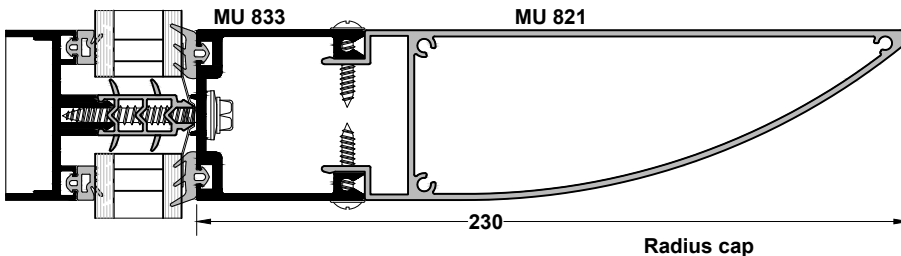

Radius cap

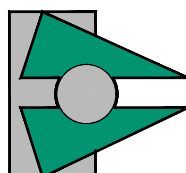

MU 800Hi - CAPPED CURTAIN WALL SYSTEM

Mullion / Transom glass assembly

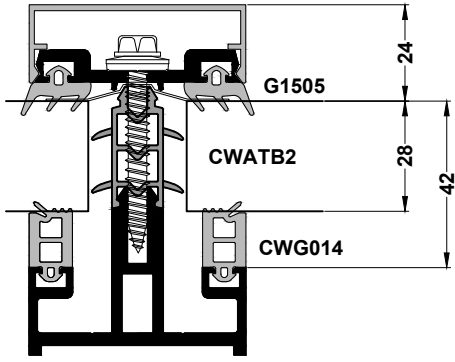

28mm Glazing

Mullion assembly

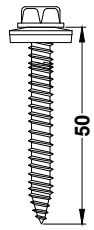

CWA050
No.14 x 50 hex
head screw with
bonded washer
(28mm glazing).

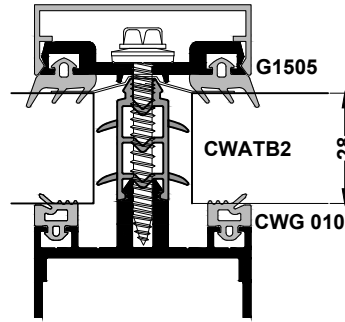

28mm Glazing

Transom assembly

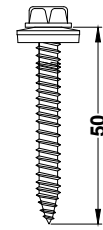

CWA050
No.14 x 50 hex
head screw with
bonded washer
(28mm glazing).

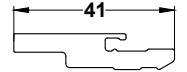

TOG06C1 - Grey
Glass support plate
28 / 32mm glazing

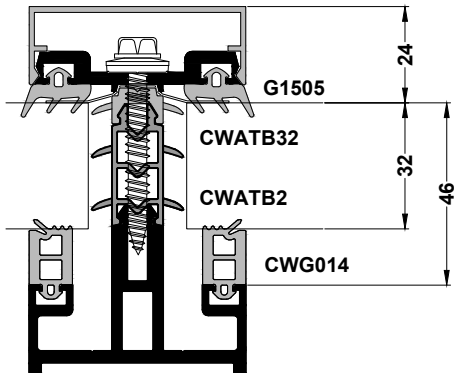

32mm Glazing

Mullion assembly

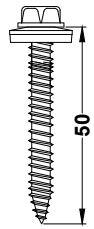

CWA050
No.14 x 50 hex
head screw with
bonded washer
(32mm glazing).

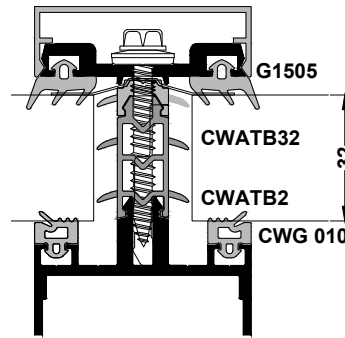

32mm Glazing

Transom assembly

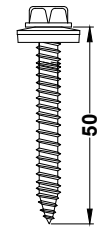

CWA050
No.14 x 50 hex
head screw with
bonded washer
(32mm glazing).

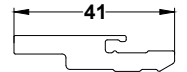

TOG06C1 - Grey
Glass support plate
28 / 32mm glazing

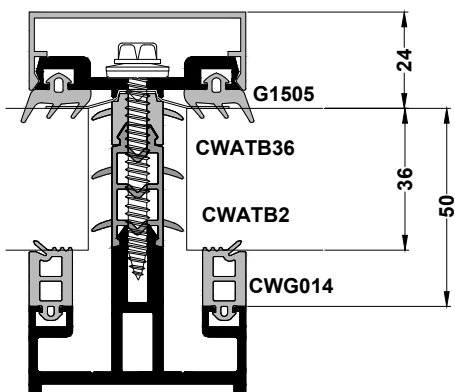

36mm Glazing

Mullion assembly

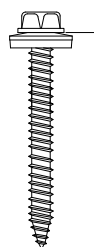

CWA055
No.14 x 55 hex
head screw with
bonded washer
(36mm glazing)

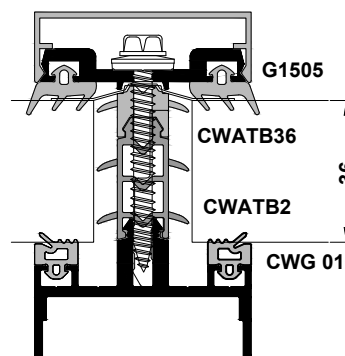

36mm Glazing

Transom assembly



CWA055
No.14 x 55 hex
head screw with
bonded washer
(36mm glazing)

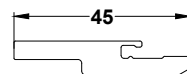

TOG07C1 - Black
Glass support plate 36mm
glazing

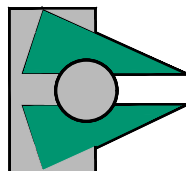

MU 800Hi - CAPPED CURTAIN WALL SYSTEM

Mullion / Transom glass assembly

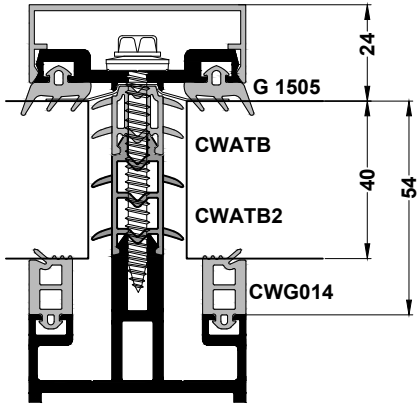

40mm Glazing

Mullion assembly

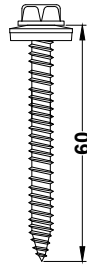

CWA060
No.14 x 60 hex head screw with bonded washer (40mm glazing).

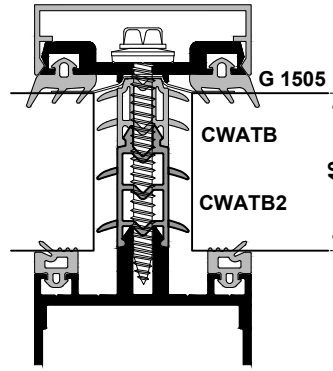

40mm Glazing

Transom assembly

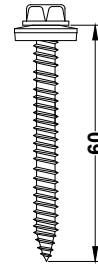

CWA060
No.14 x 60 hex head screw with bonded washer (40mm glazing).

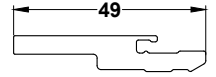

TOG09C1 - Blue
Glass support plate
40mm glazing

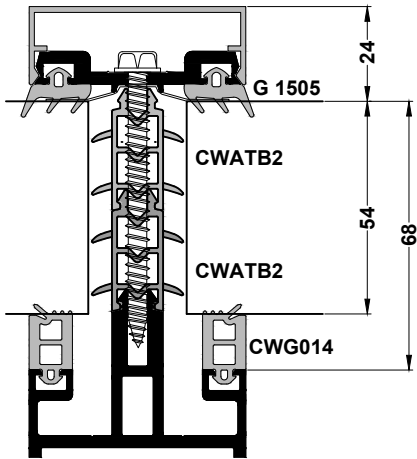

54mm Glazing

Mullion assembly

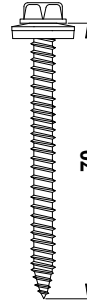

CWA070
No.14 x 70 hex head screw with bonded washer (54mm glazing).

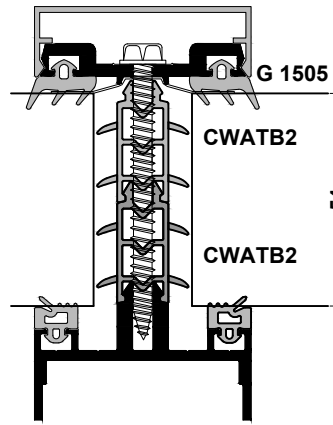

54mm Glazing

Transom assembly

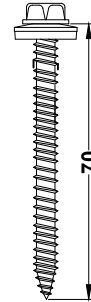

CWA070
No.14 x 70 hex head screw with bonded washer (54mm glazing).

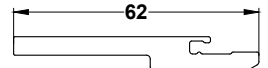

TOG10C1 - Green
Glass support plate
54mm glazing

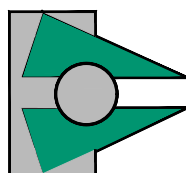

MU 800Hi - CAPPED CURTAIN WALL SYSTEM

Typical head detail

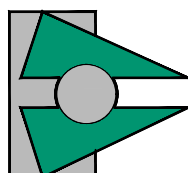
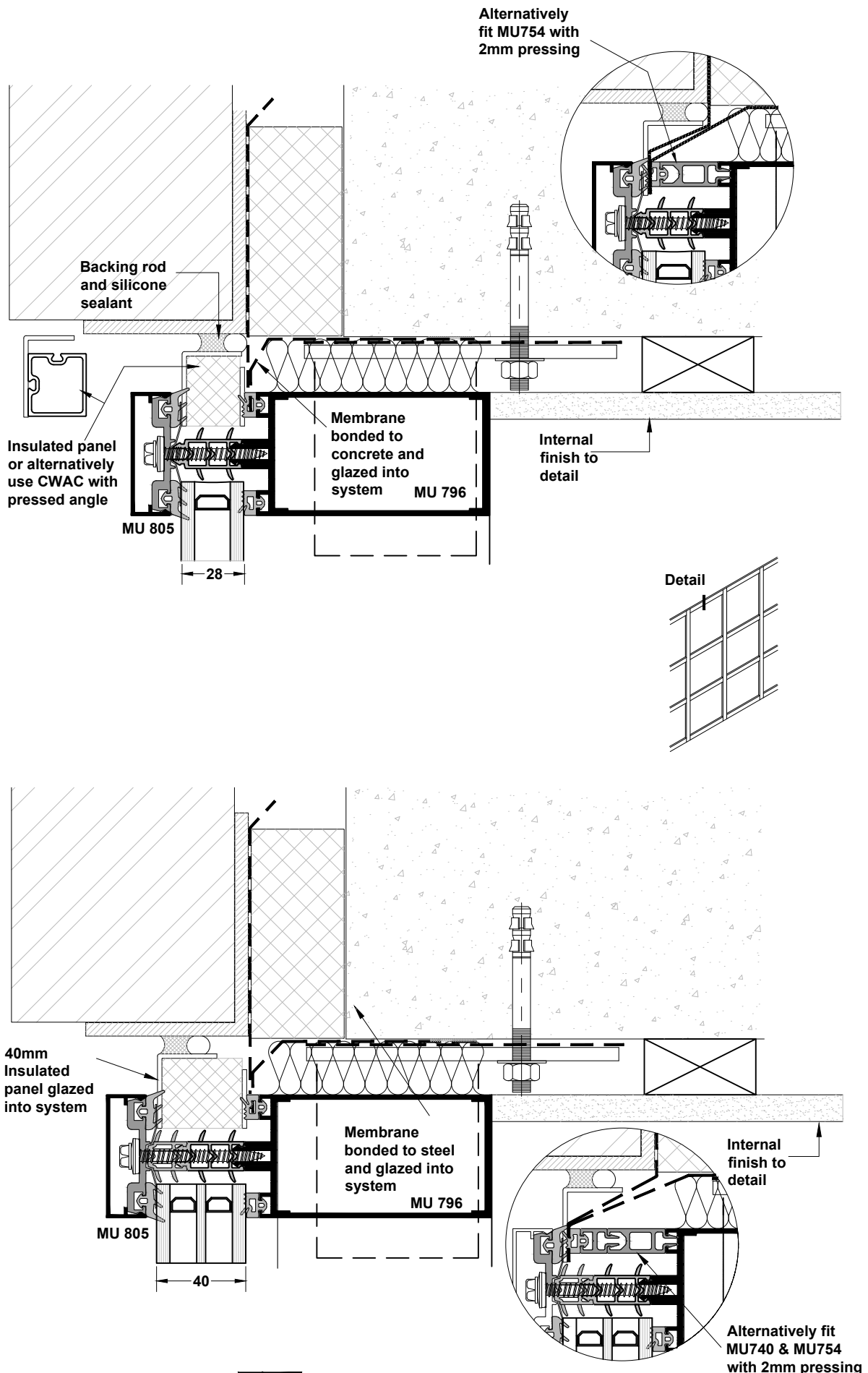

MU 800Hi - CAPPED CURTAIN WALL SYSTEM

Typical head detail with Kingspan cladding

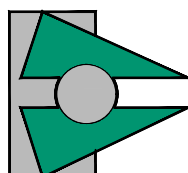
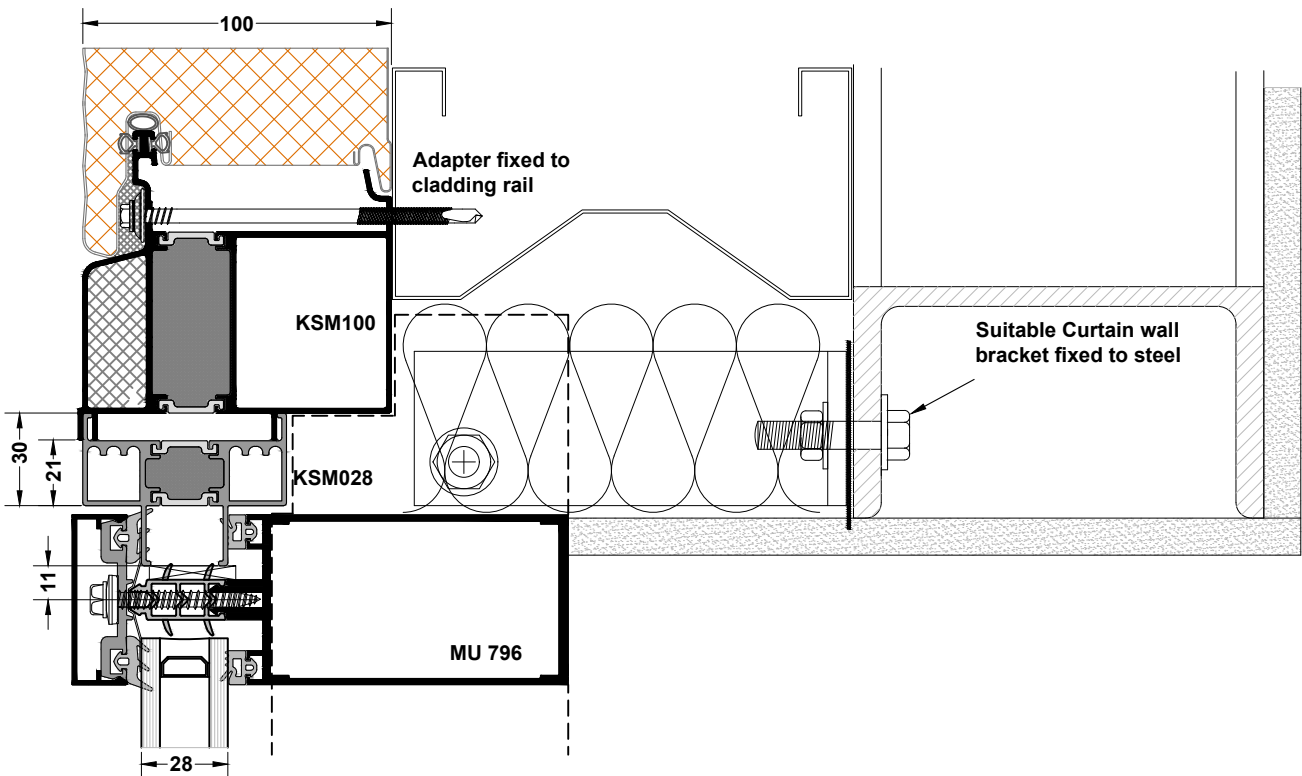
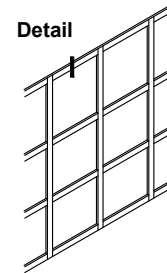
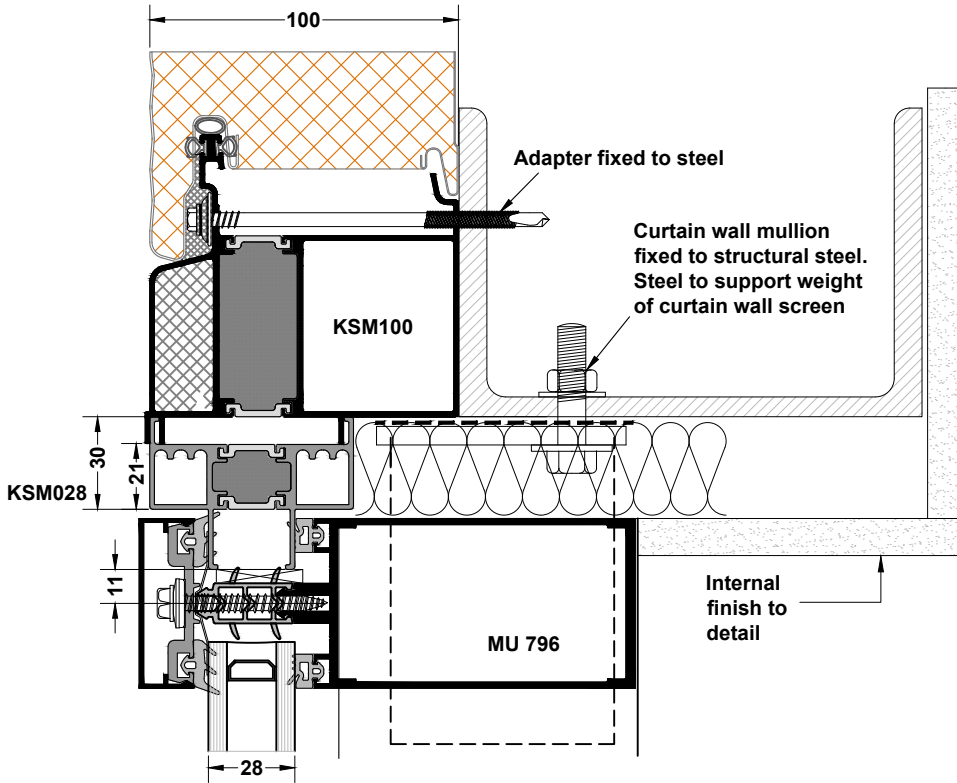

MU 800Hi - CAPPED CURTAIN WALL SYSTEM

Typical cill detail

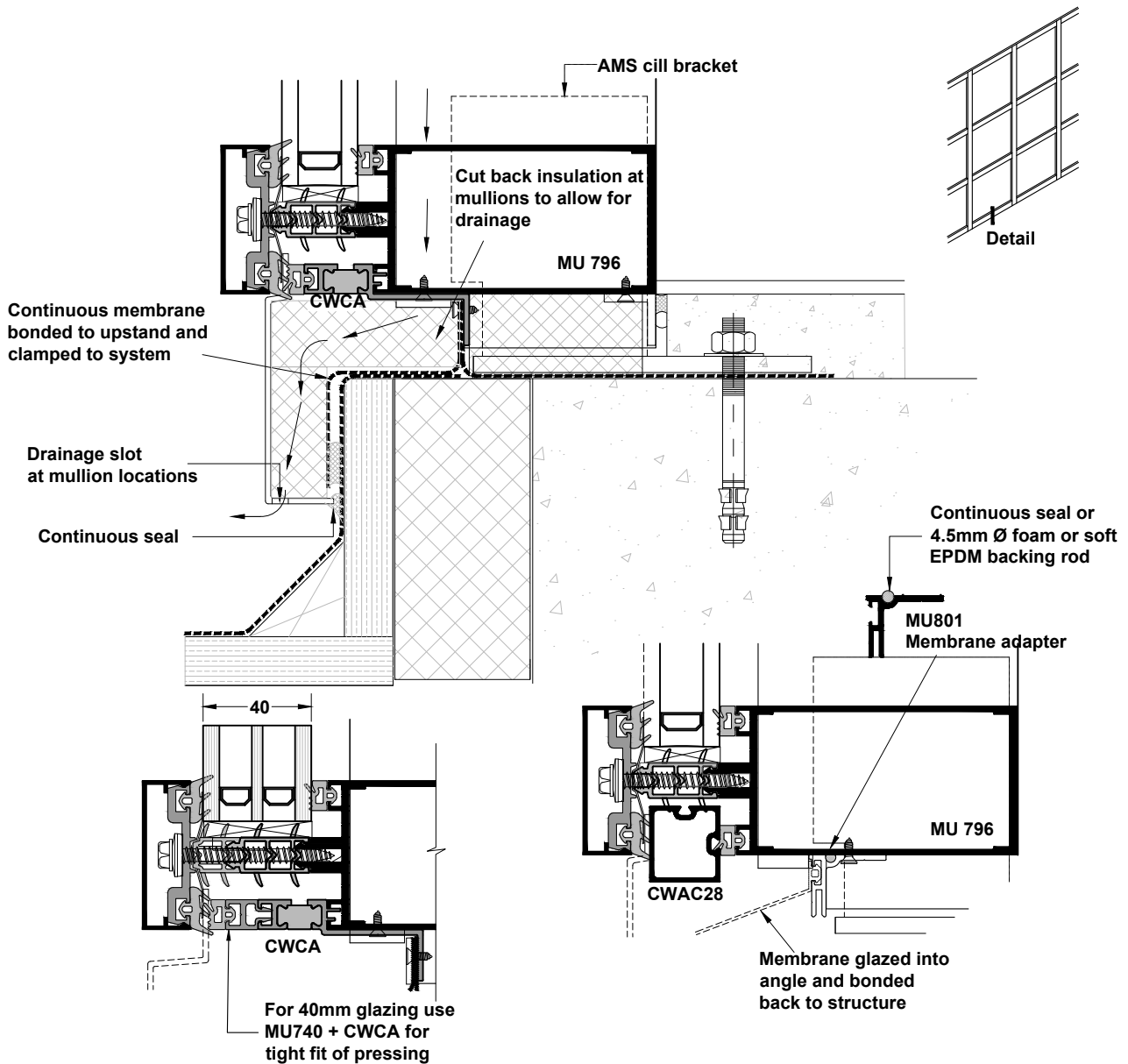

Drainage spouts may be fitted in certain locations where it is not possible to fit a flashing e.g. door jambs or where mullion sits on a transom or inside the mullion; in-between the transoms. Spouts should not be used as the primary defence against water ingress at a cill level.

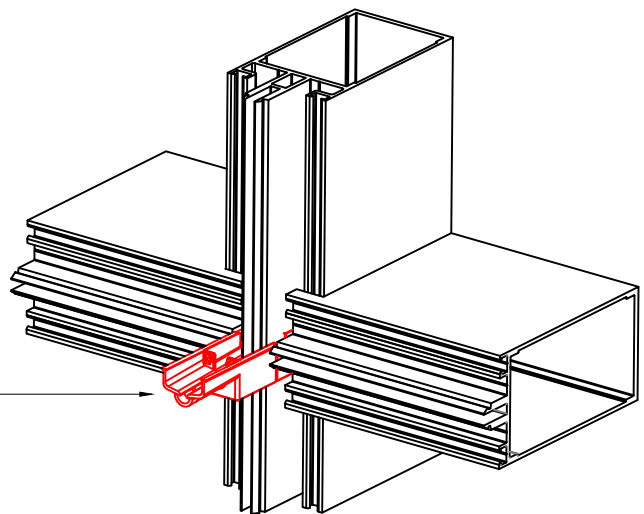
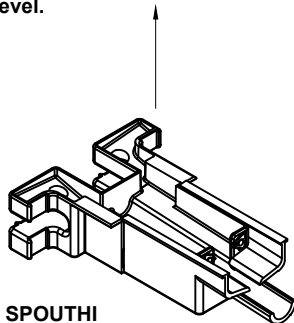

Drainage Spout (SPOUTHI) fitted inside the mullion; in-between the transoms

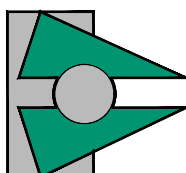

MU 800Hi - CAPPED CURTAIN WALL SYSTEM

Typical fixing detail - splice joint

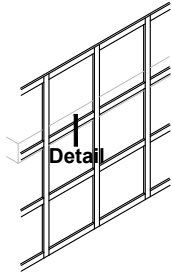

Splice cover (CWASC) is used for splice joint protection and sealing, allowing water drain through the curtain wall system and across splice joints.

Note:
On screens higher than 15m; fit a splice cover (CWASC) at each splice joint location and also a drainage spout (SPOUTHI) in the transom area just above the splice joint.

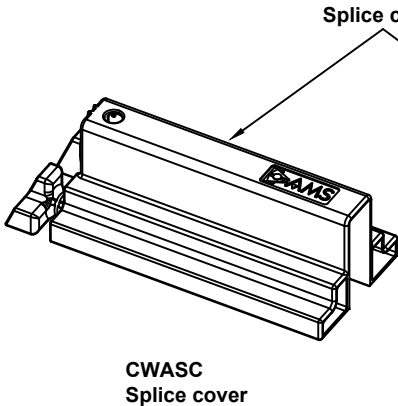
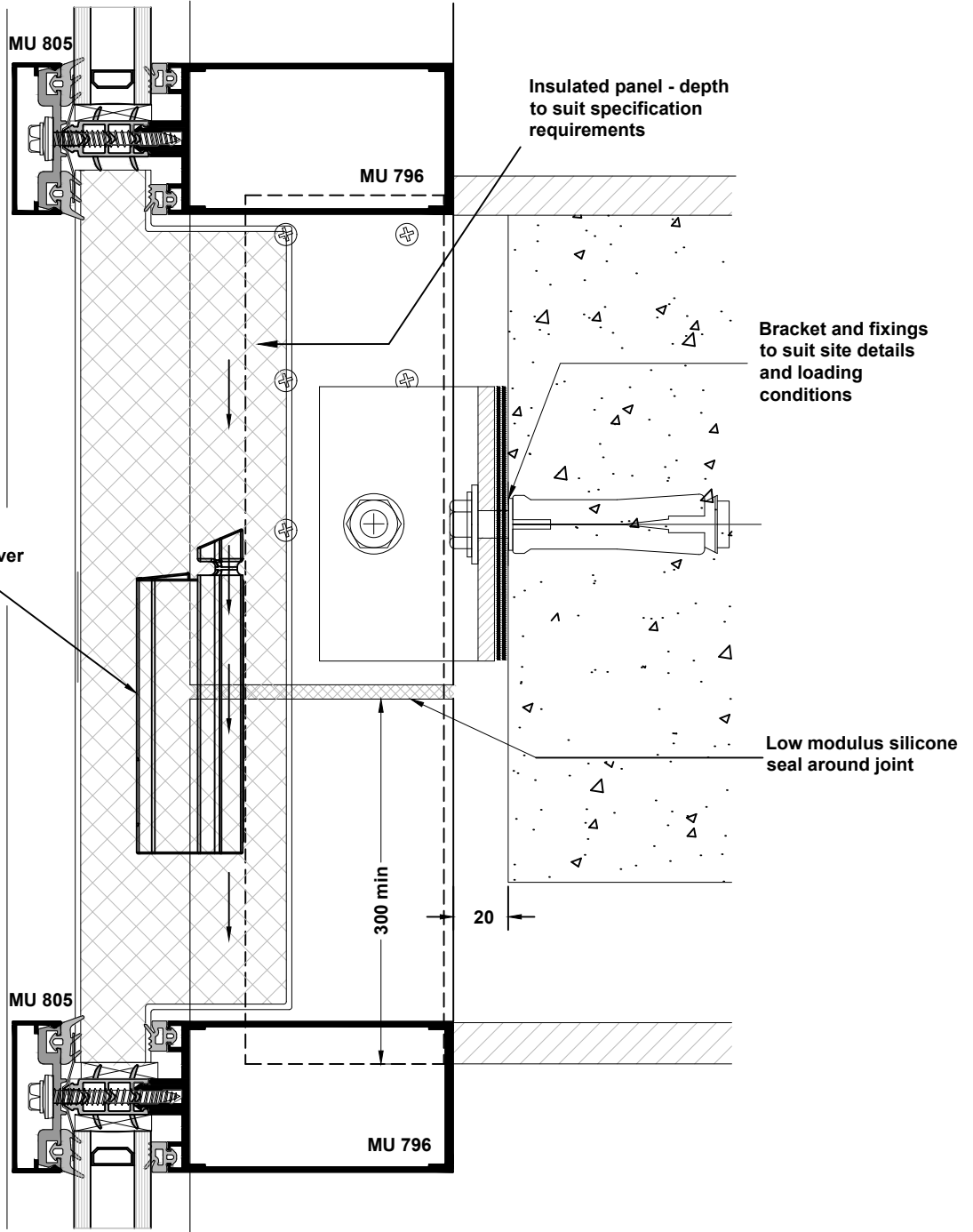

Splice cover to be slid into the top or bottom profile and when mullions are set on site slide it over the splice joint and seal.

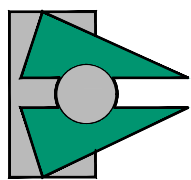

MU 800Hi - CAPPED CURTAIN WALL SYSTEM

Typical fixing detail - splice detail

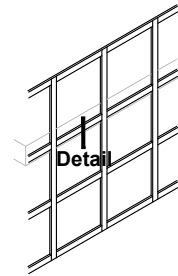

Note:
On screens higher than 15m;
fit a splice cover (CWASC) at
each splice joint location and
also a drainage spout
(SPOUTHI) in the transom
area just above the splice
joint.

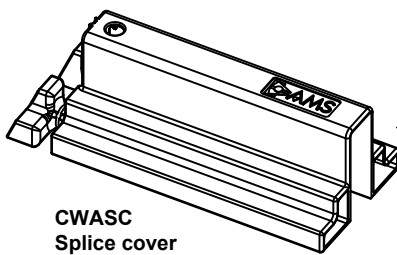

**CWASC
Splice cover**

Splice cover to be slid into the top
or bottom profile and when
mullions are set on site slide it
over the splice joint and seal.

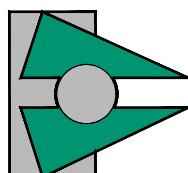
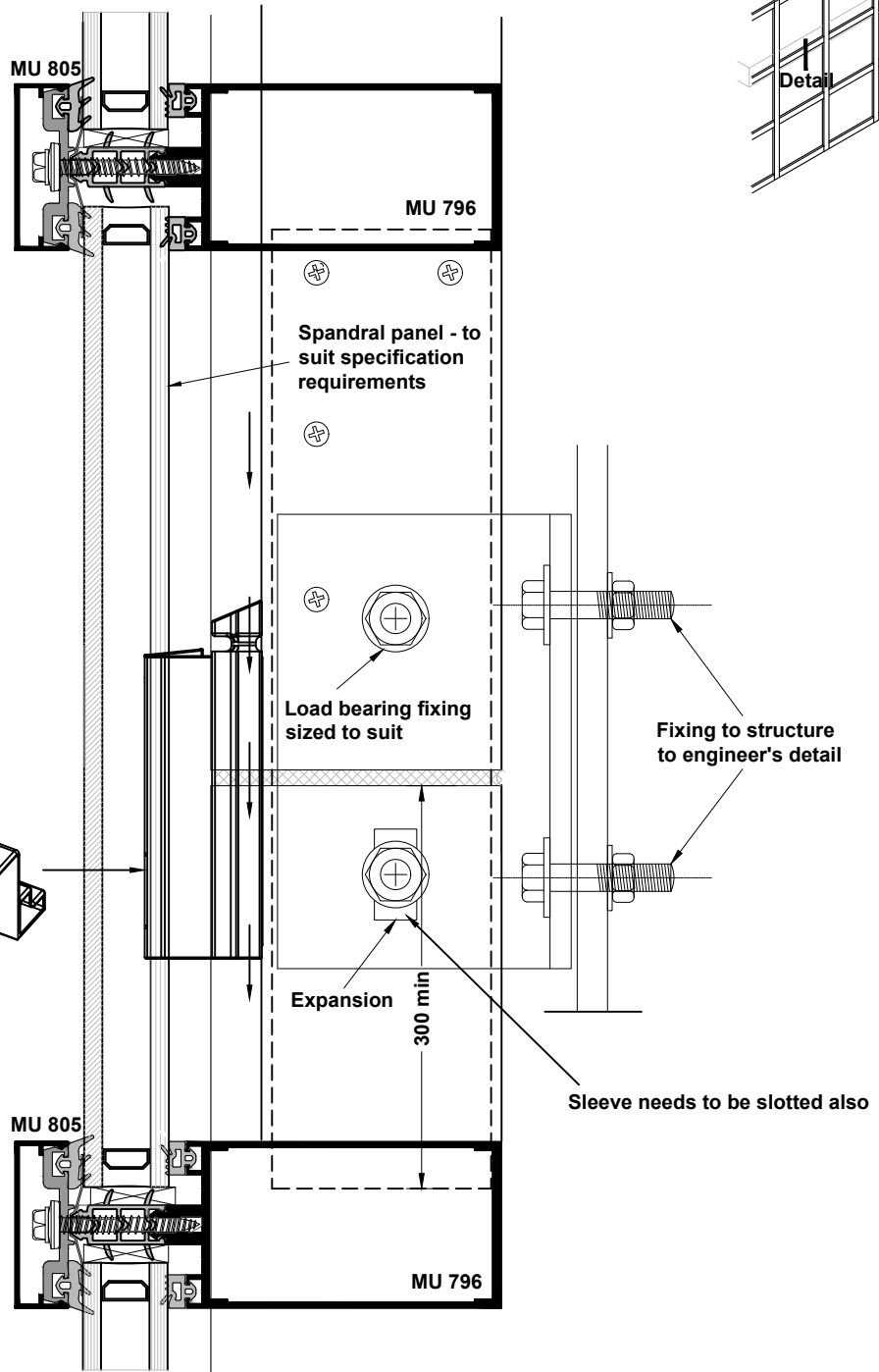

MU 800Hi - CAPPED CURTAIN WALL SYSTEM

Sash insert details

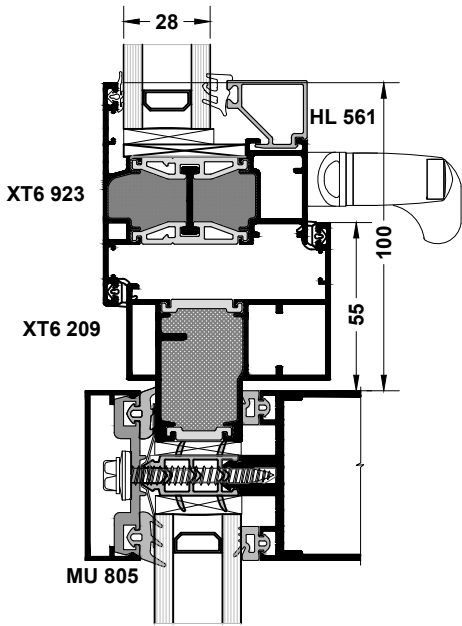

Casement insert
28mm glazing

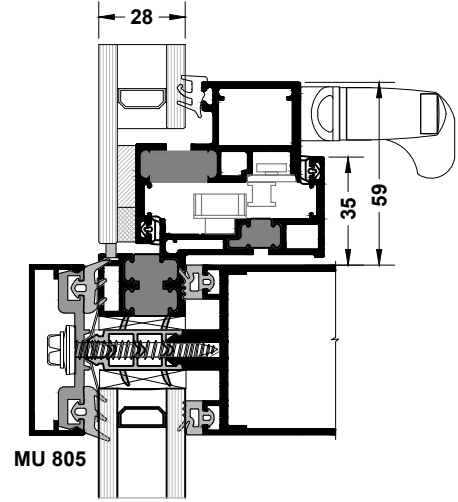
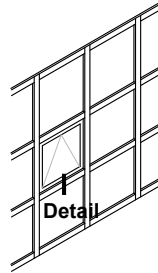

Bonded sash insert
28mm glazing



MU736
Packer for 36 mm
glazing inserts

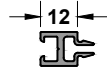

MU740
Packer for 40mm
glazing inserts

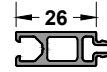

MU754
Packer for 54mm
glazing inserts

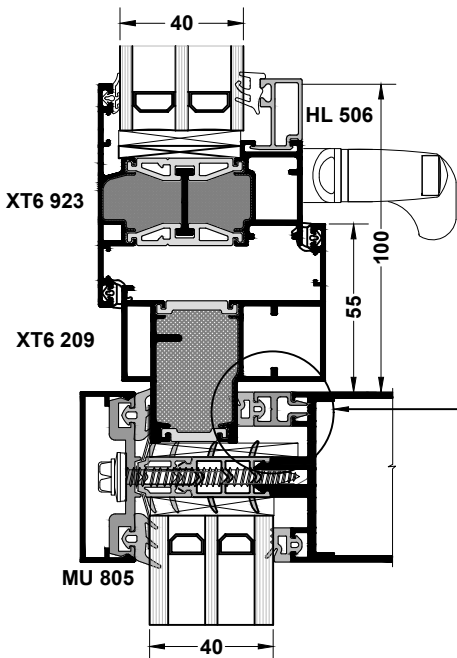

Casement insert
40mm glazing

For 36mm glazing fit MU736
For 40mm glazing fit MU740
For 54mm glazing fit MU754

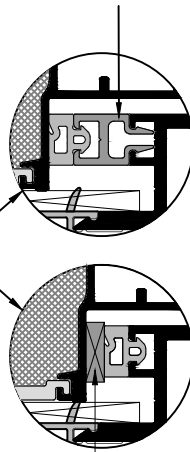

For 32mm glazing
4mm packer required

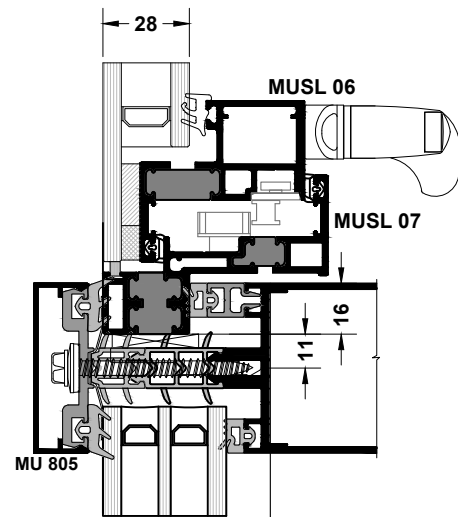

Bonded sash insert
40mm glazing

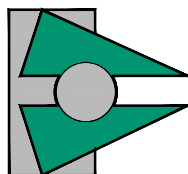

MU 800Hi - CAPPED CURTAIN WALL SYSTEM

Door insert details

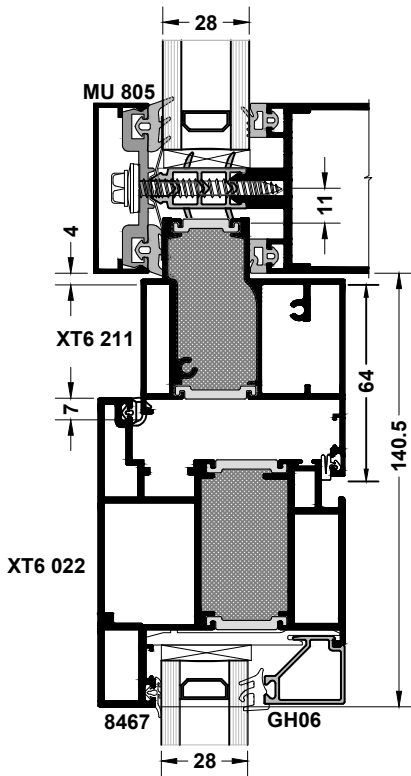

Door insert: Open out 28mm glazing.
For open in doors use
XT6212 frame and XT6026 door sash

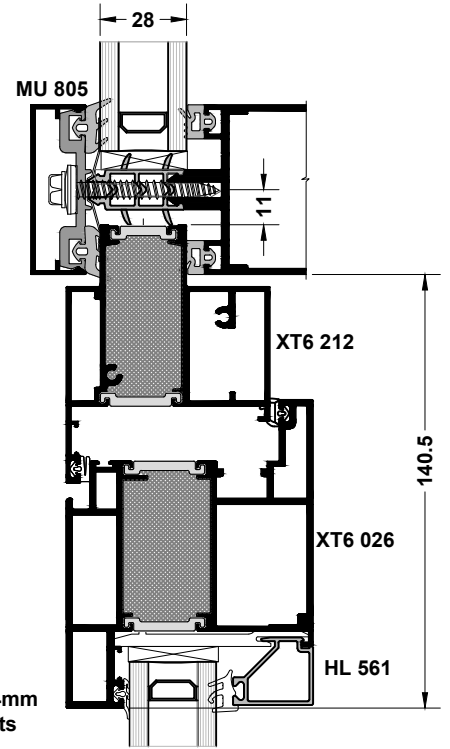

Door insert: Open in 28mm glazing



MU736
Packer for 36 mm
glazing inserts

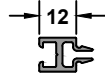

MU740
Packer for 40mm
glazing inserts

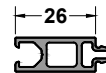

MU754
Packer for 54mm
glazing inserts

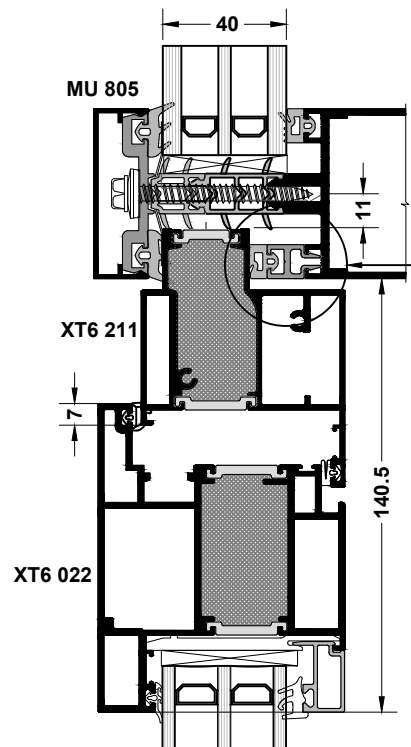

Door insert: Open out 40mm glazing.
For open in doors use
XT6212 frame and XT6026 door sash

For 36mm glazing fit MU736
For 40mm glazing fit MU740
For 54mm glazing fit MU754

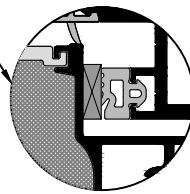
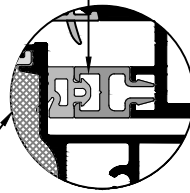

For 32mm glazing
4mm packer required

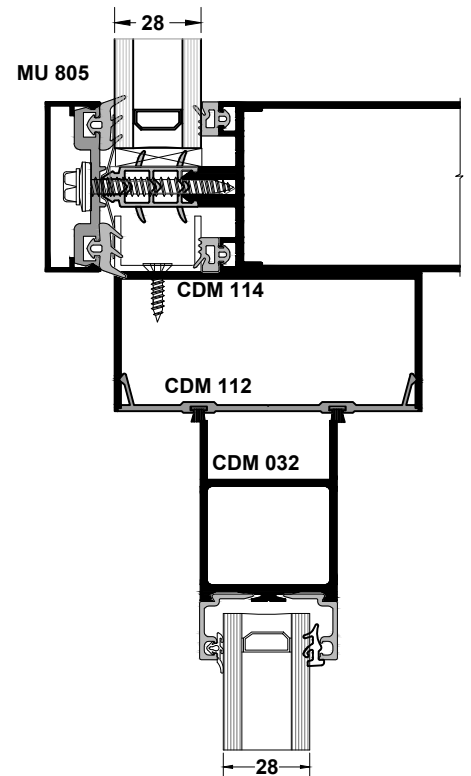

Commercial door into curtain wall

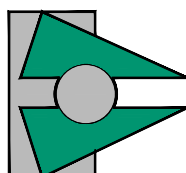

MU 800Hi - CAPPED CURTAIN WALL SYSTEM

Typical jamb detail

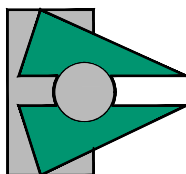
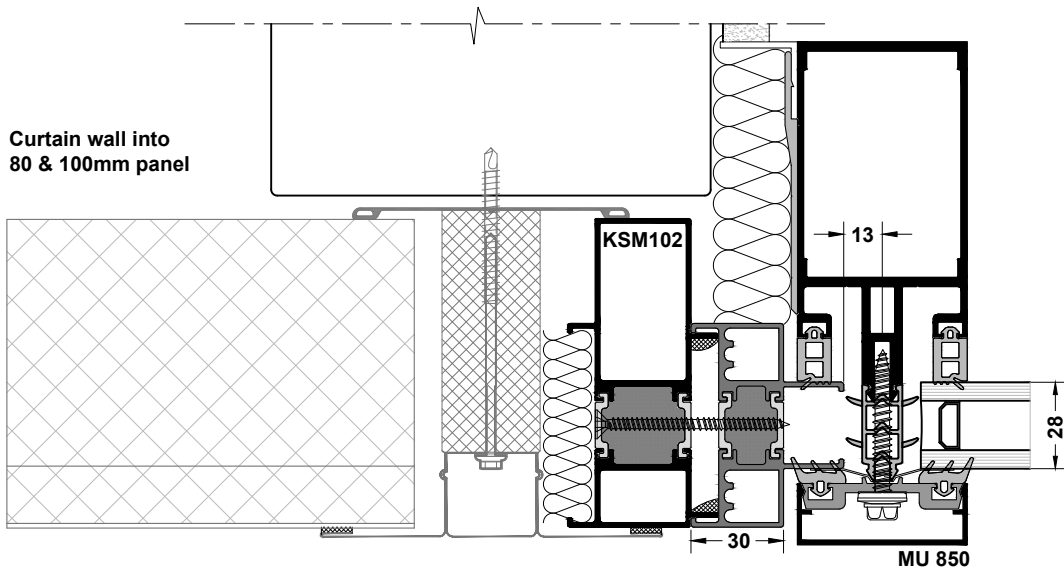
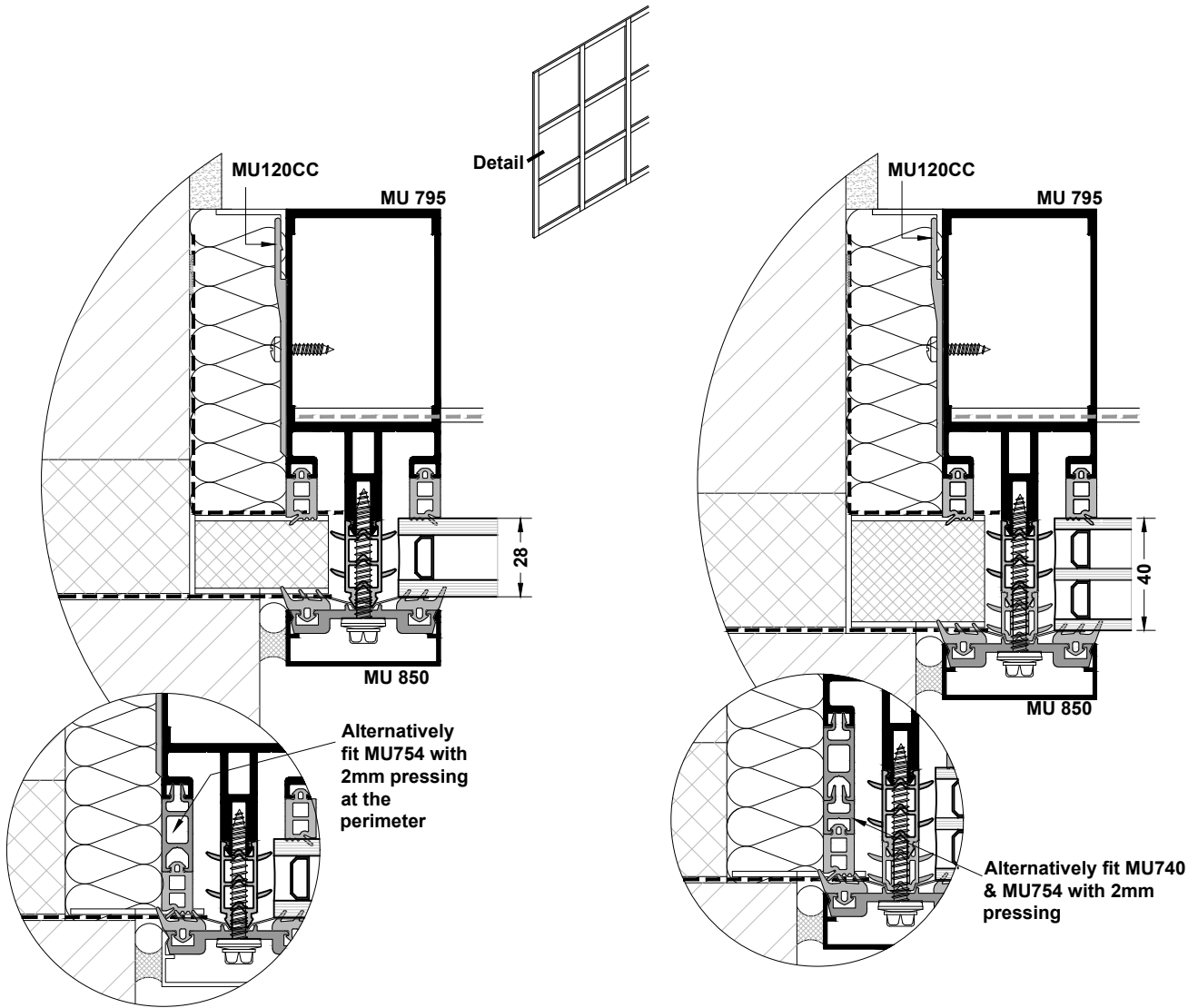

MU 800Hi - CAPPED CURTAIN WALL SYSTEM

Typical door jamb detail

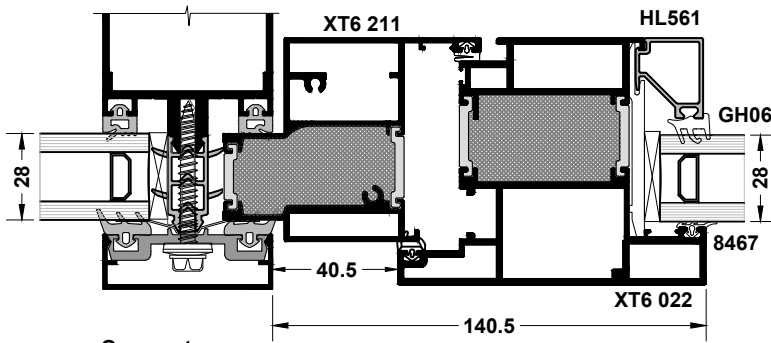

Open out,
internally glazed XT66 rebate door

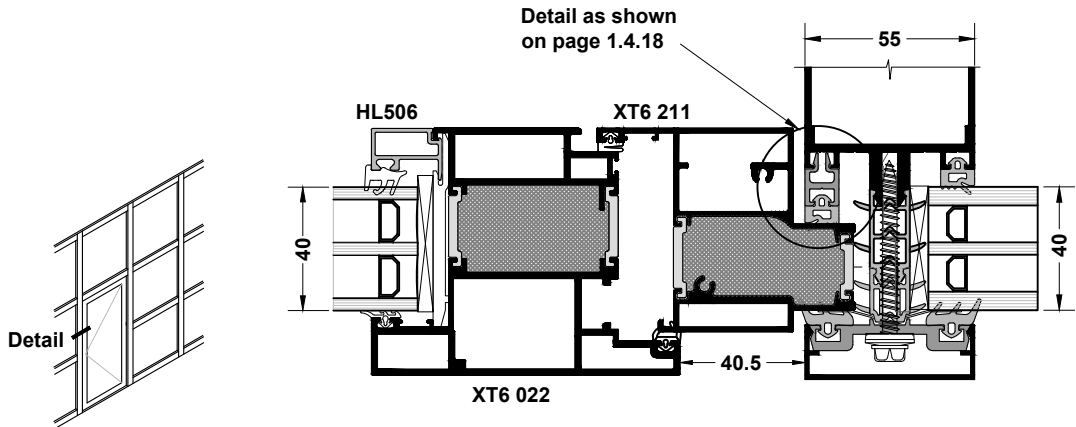

Open out, internally glazed XT66 rebate door,
40mm glazing

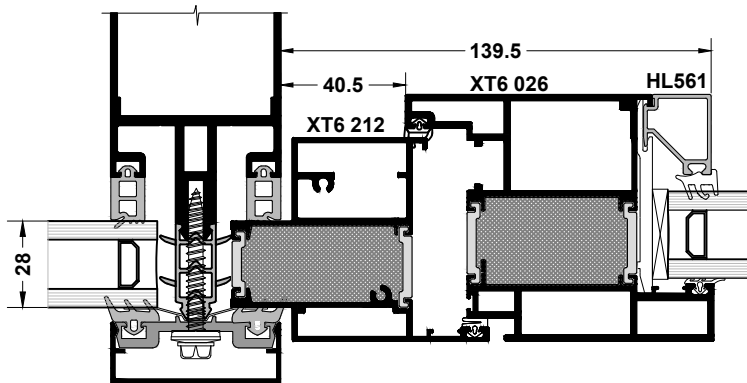

Open in, internally glazed XT66 rebate door
(40mm Triple glazing achievable as per open
out detail shown above)

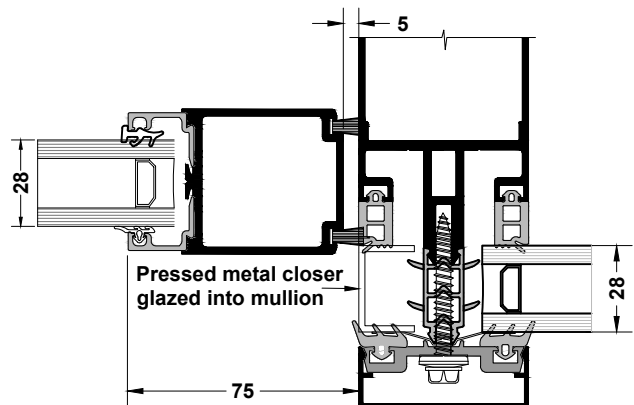

Commercial door into curtain wall
(Max thickness of glass into commercial door is 28mm)

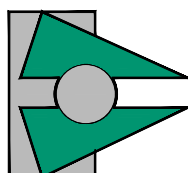

MU 800Hi - CAPPED CURTAIN WALL SYSTEM

Corner assemblies

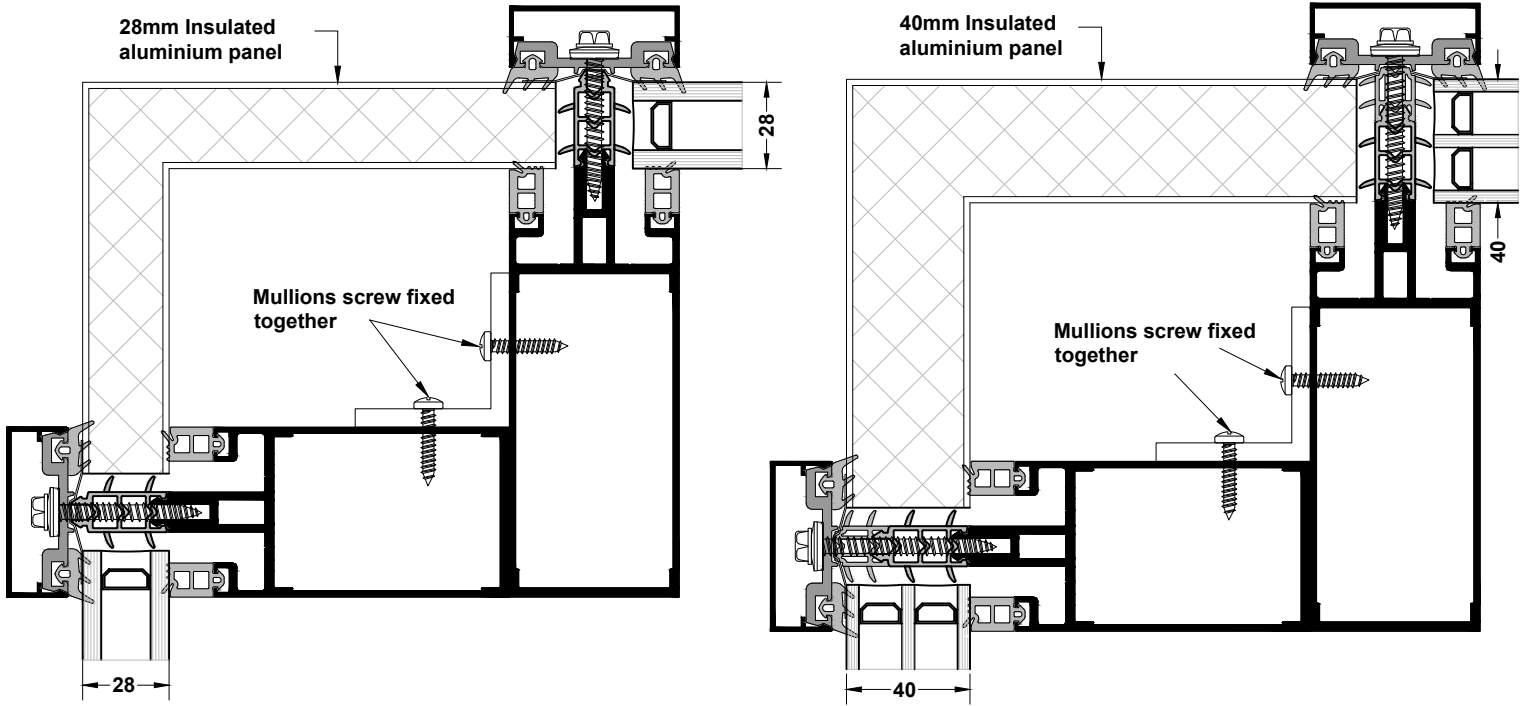

External corner with MU 795 & MU 782

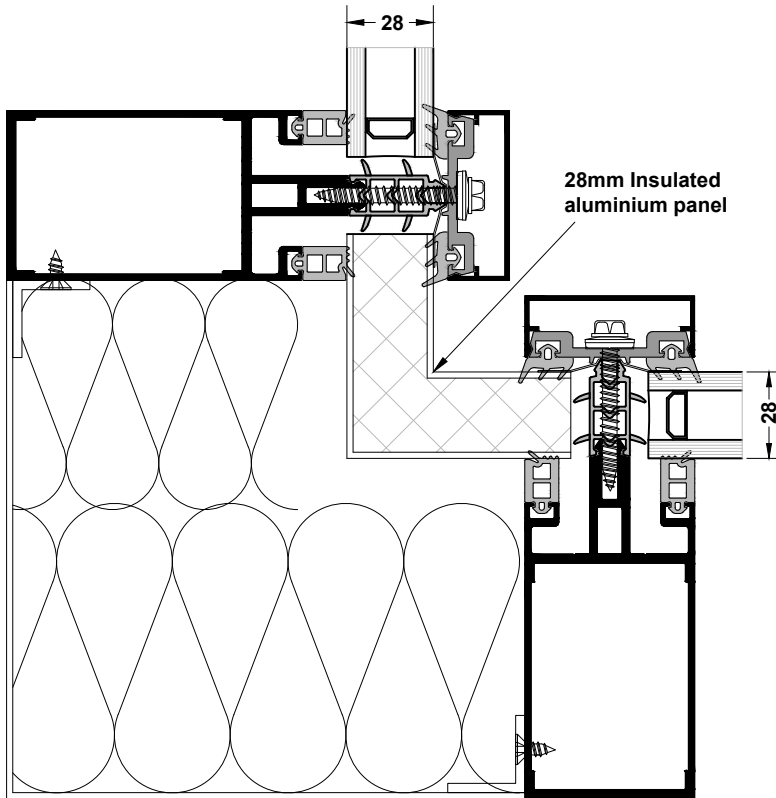

Internal corner with MU 795

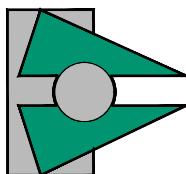
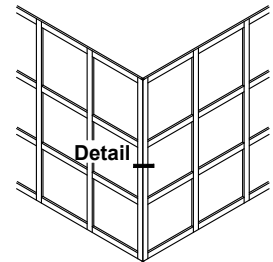

MU 800Hi - CAPPED CURTAIN WALL SYSTEM

Typical head detail - sloped glazing

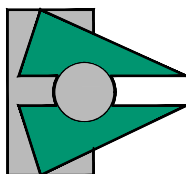
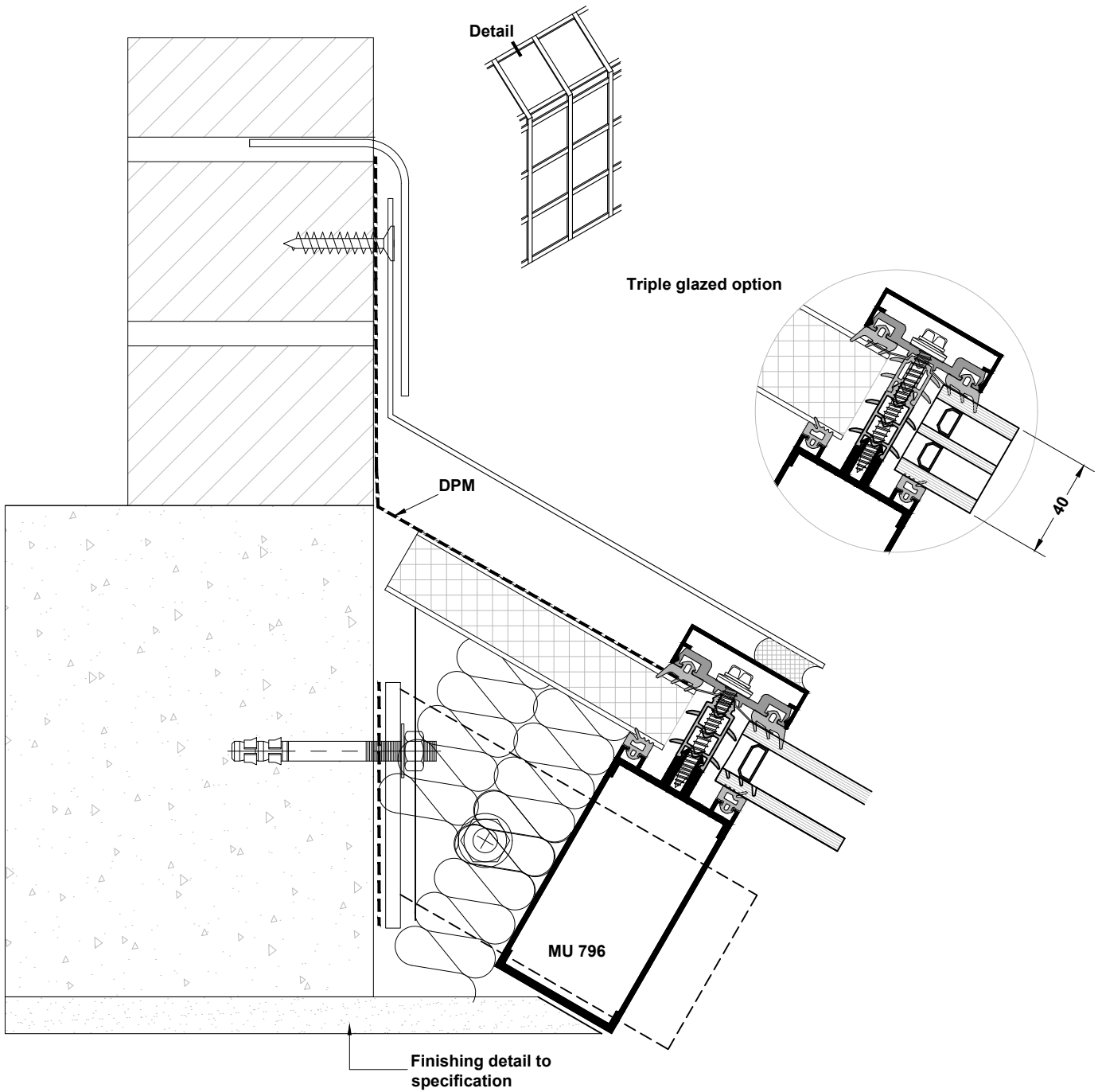

MU 800Hi - CAPPED CURTAIN WALL SYSTEM

Typical eaves detail

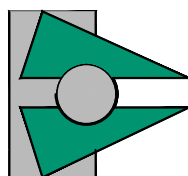
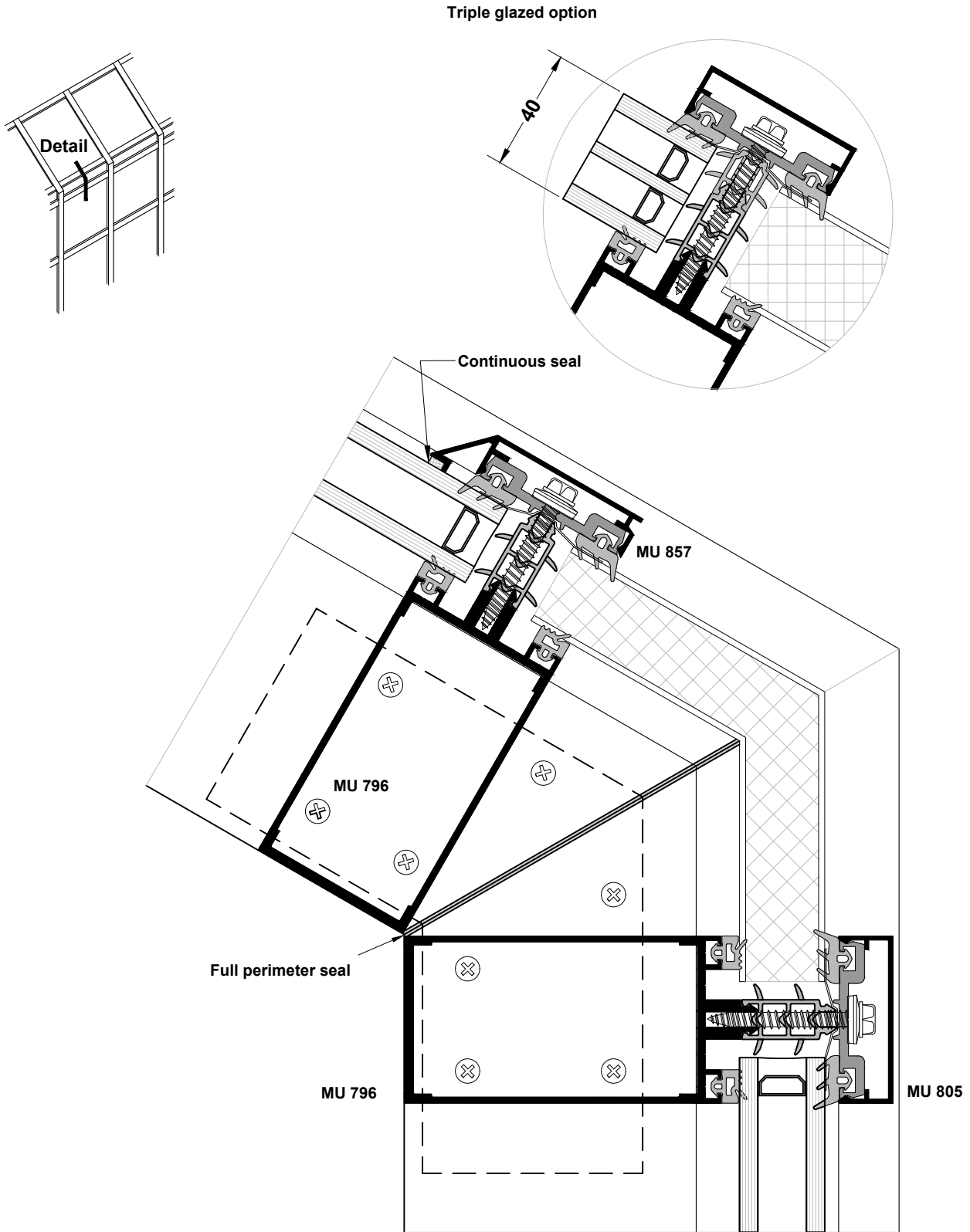

MU 800Hi - CAPPED CURTAIN WALL SYSTEM

Typical ridge details

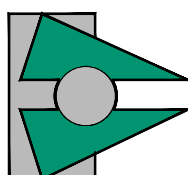
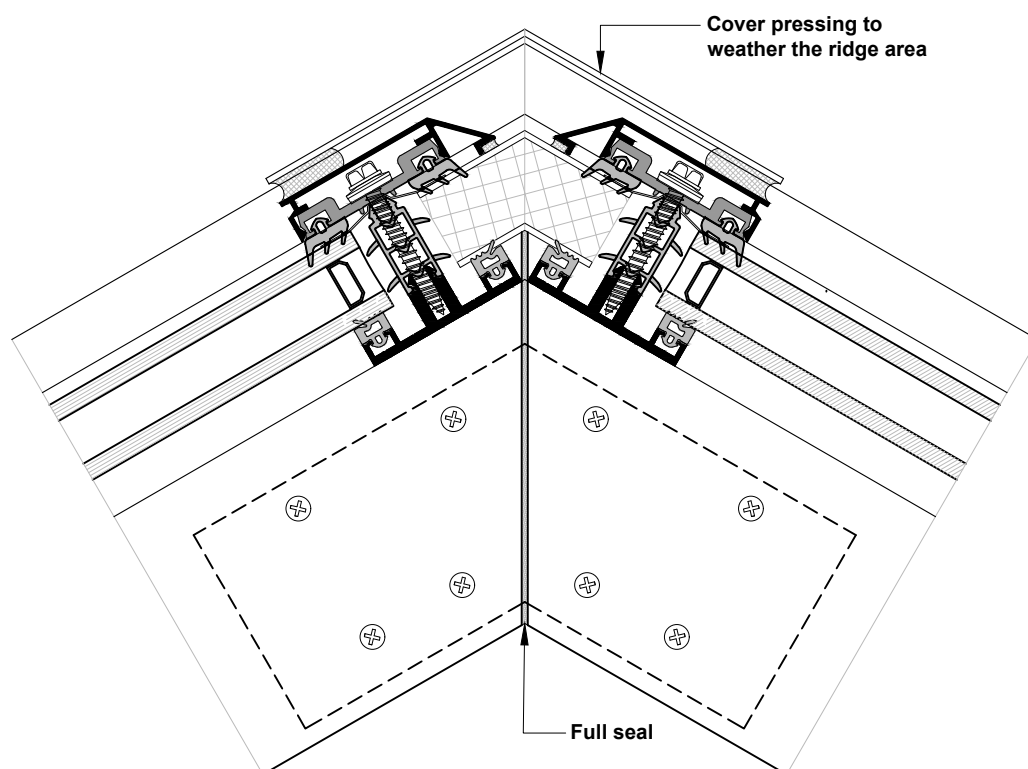
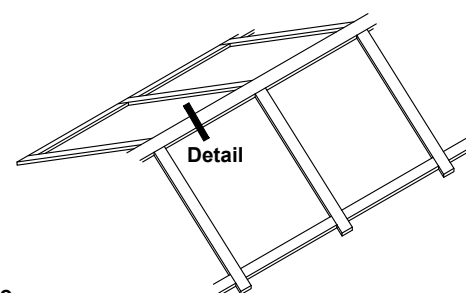
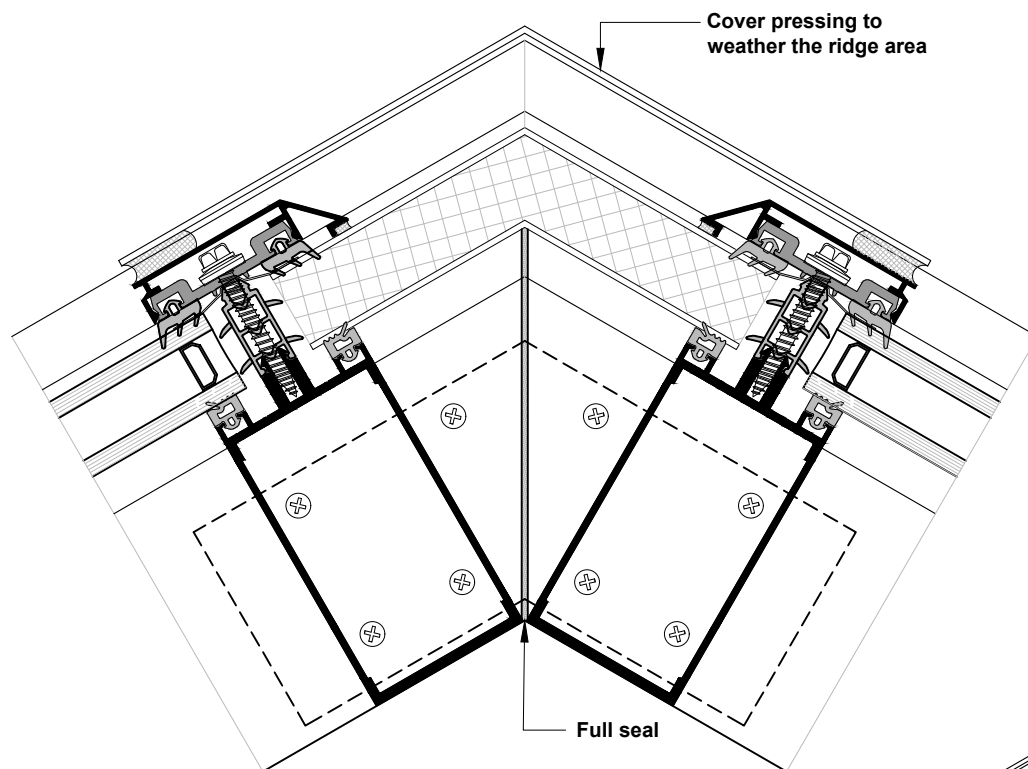

MU 800Hi - CAPPED CURTAIN WALL SYSTEM

Typical cill details - sloped glazing

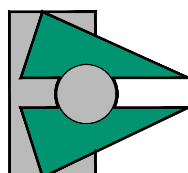
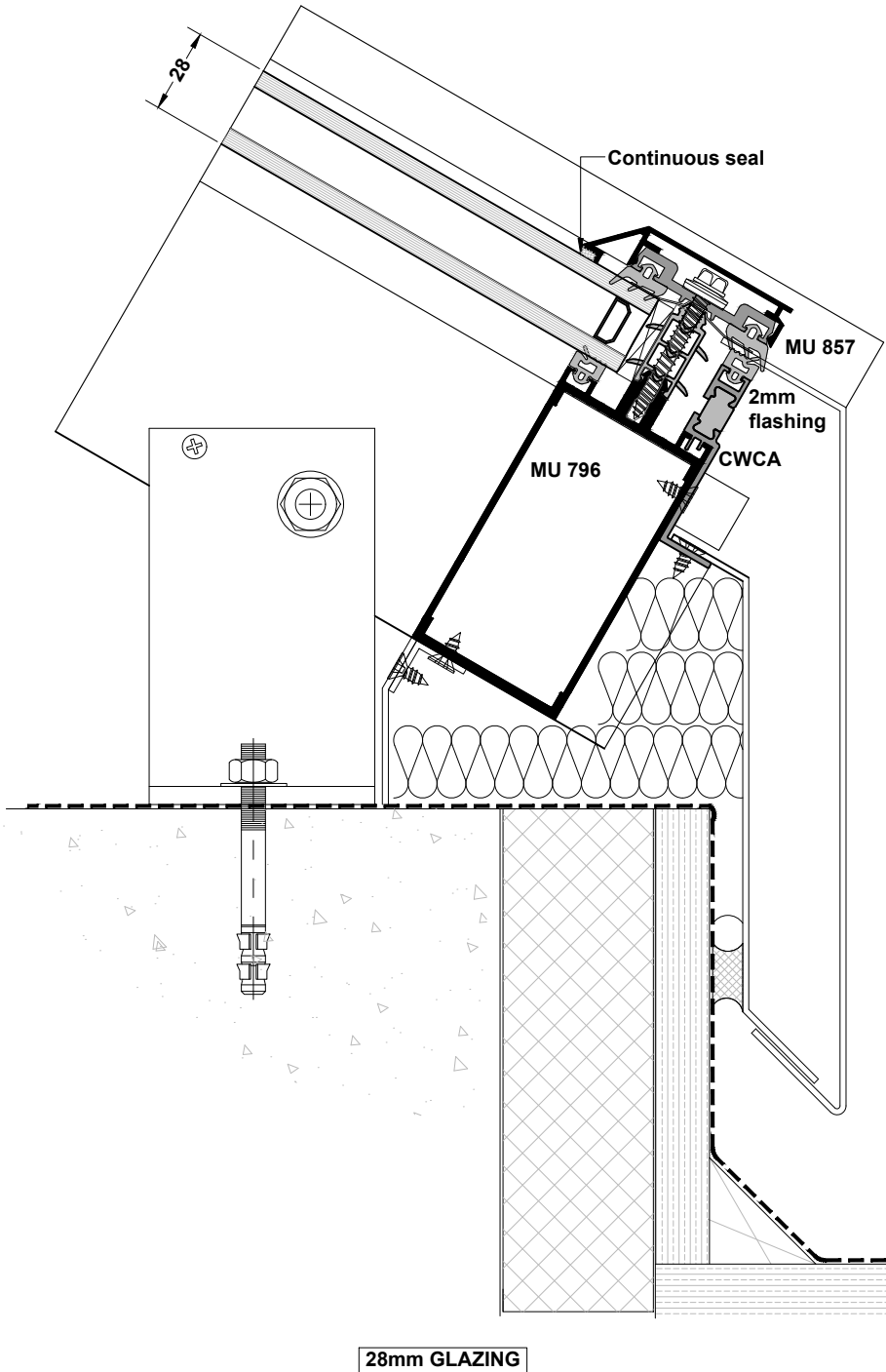
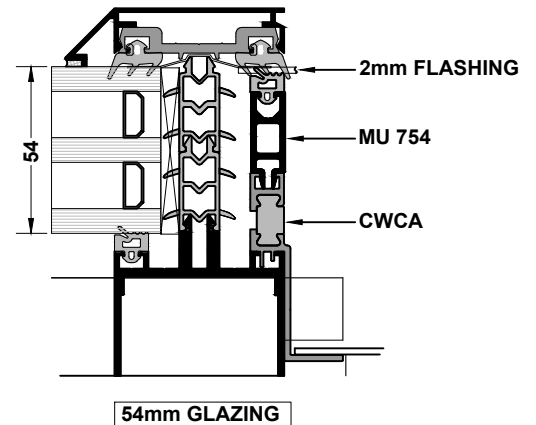
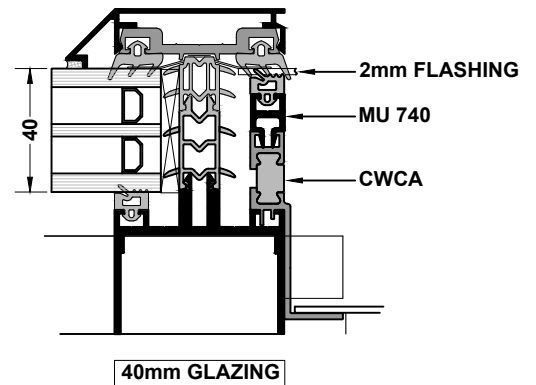
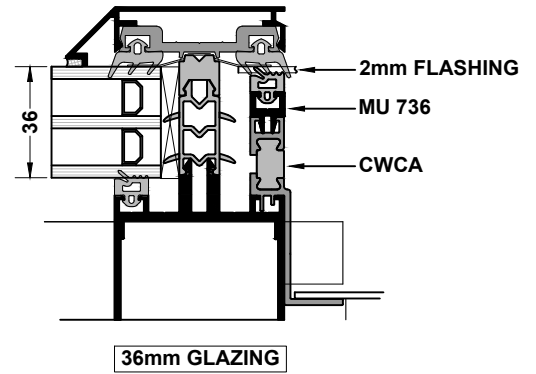
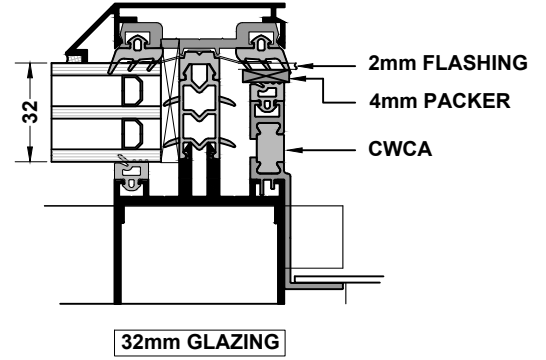
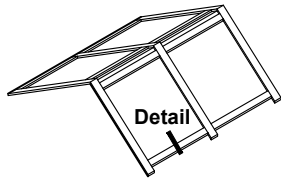

MU 800Hi - CAPPED CURTAIN WALL SYSTEM

False Mullion / Transom detail

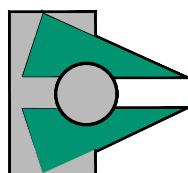
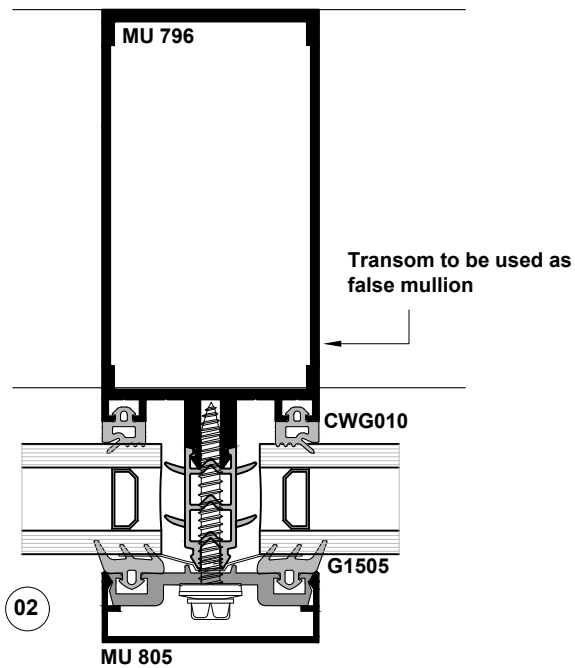
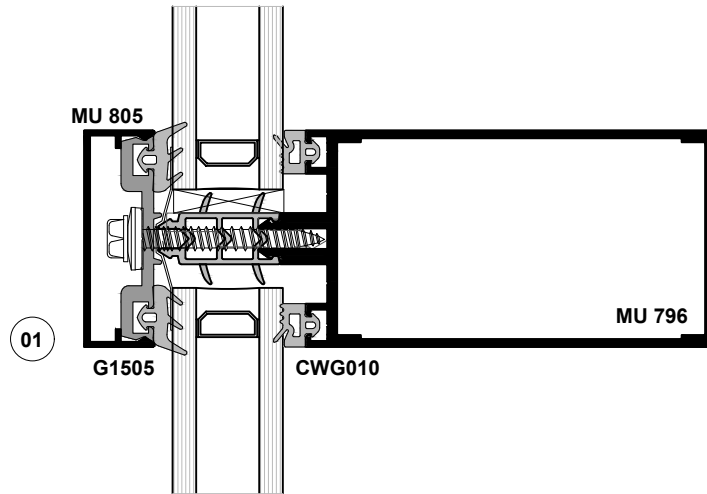
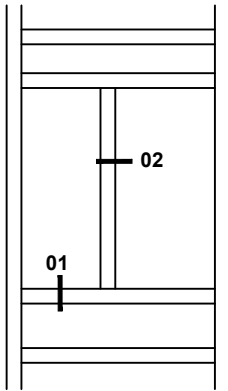

MU 800Hi - CAPPED CURTAIN WALL SYSTEM

Mullion - Matrix capping details

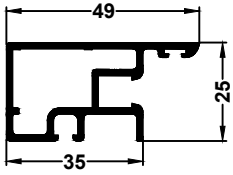

MUSL 04
Extended 'Matrix' Capping

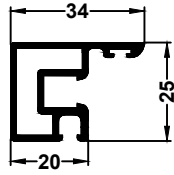

MUSL 01
'Matrix' Capping

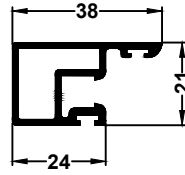

MUSL 05
'Matrix' Capping



5.1 x 1200
Woolpile (CDA016)



8471
Matrix flipper gasket



4.8 x 450
Woolpile for cap

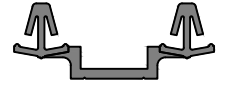

MUSL CLIP
Matrix Clip

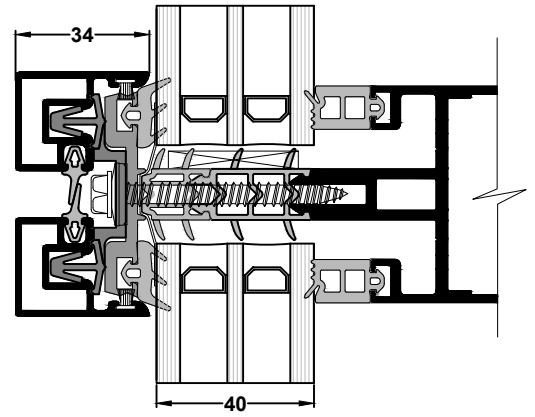
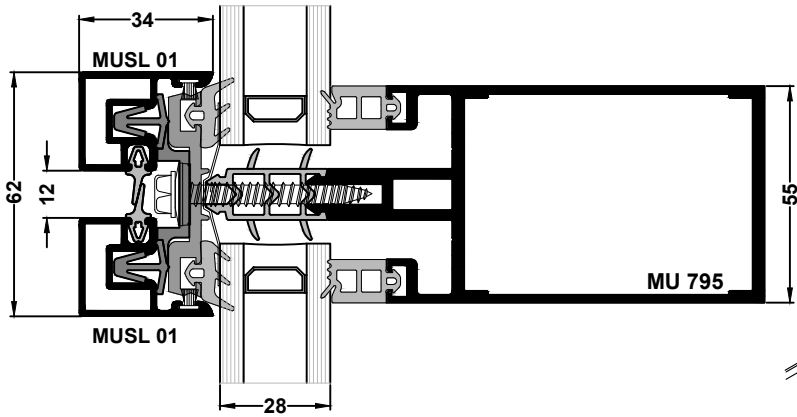

Detail

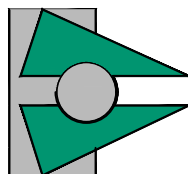
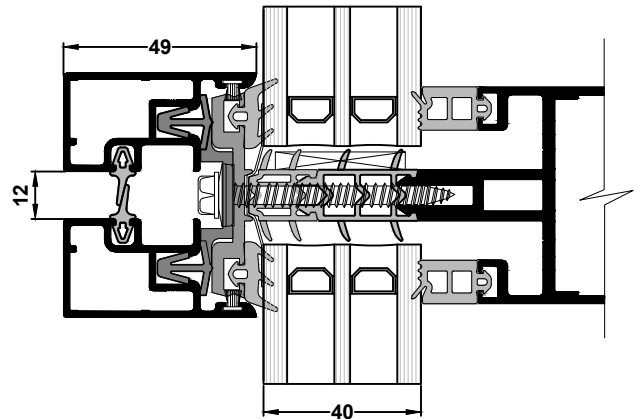
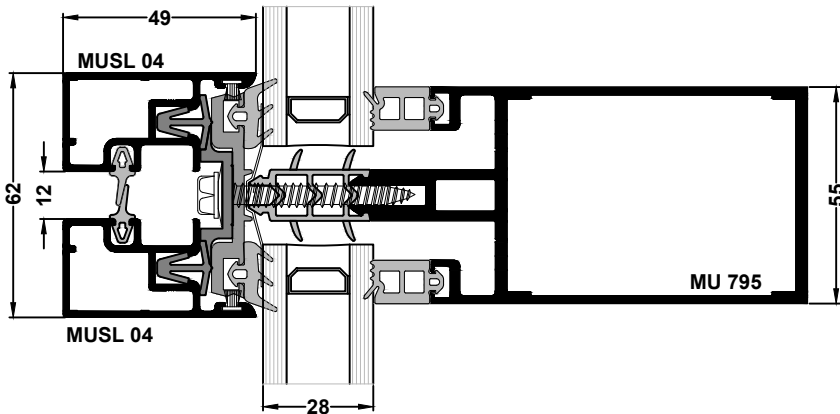
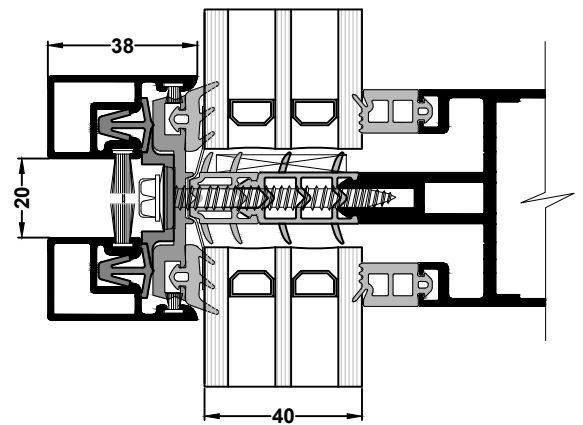
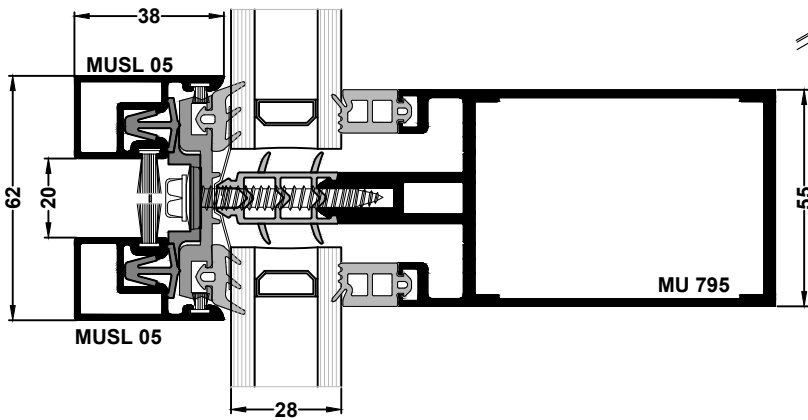

MU 800Hi - CAPPED CURTAIN WALL SYSTEM

Transom - Matrix capping details

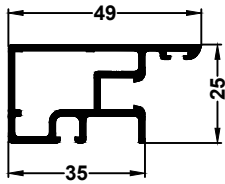

MUSL 04
Extended 'Matrix' Capping

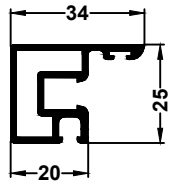

MUSL 01
'Matrix' Capping

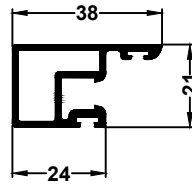

MUSL 05
'Matrix' Capping

5.1 x 1200
Woolpile (CDA016)

4.8 x 450
Woolpile for cap

8471
Matrix flipper gasket

MUSL CLIP
Matrix Clip

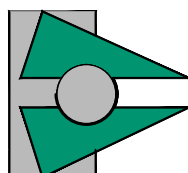
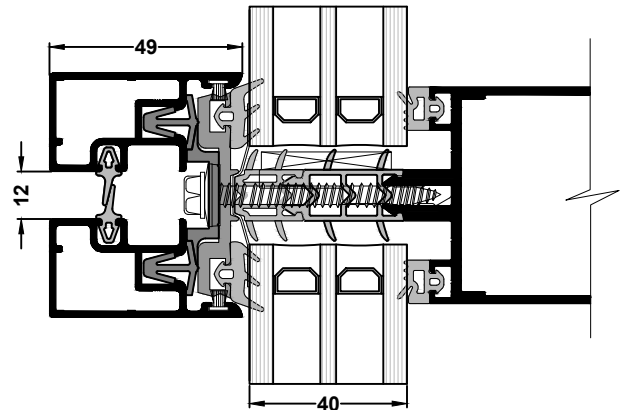
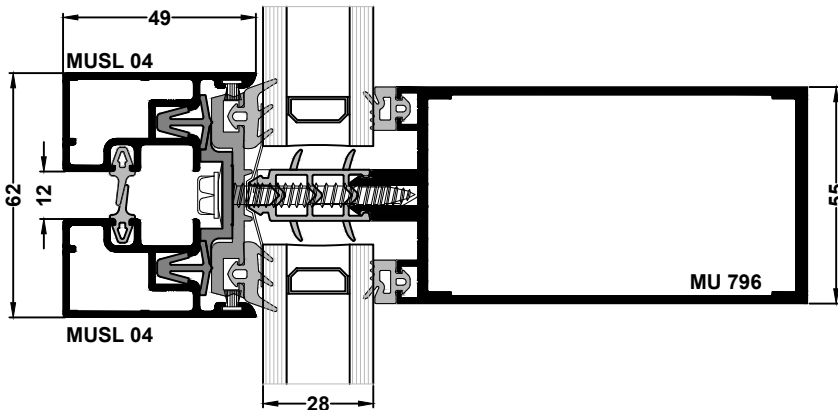
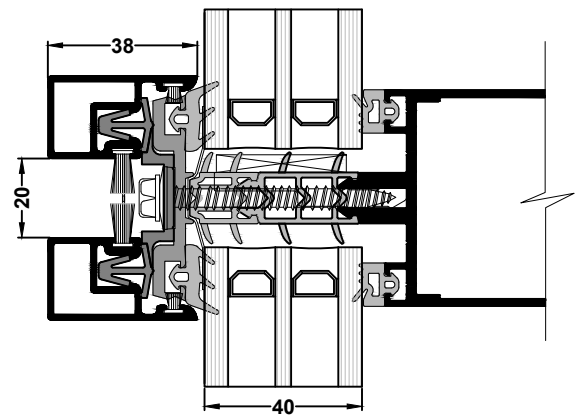
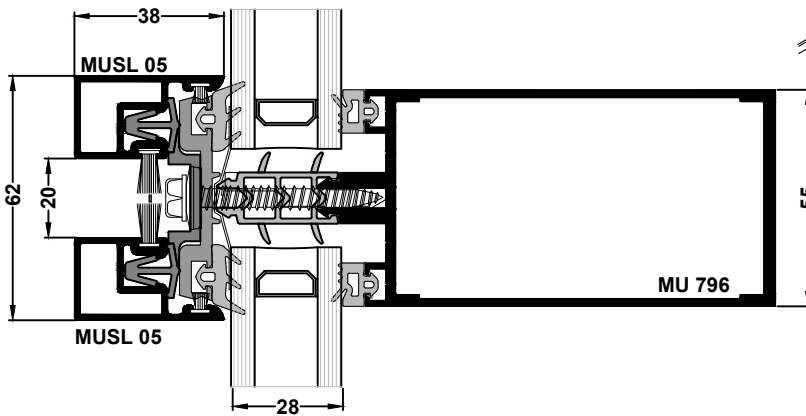
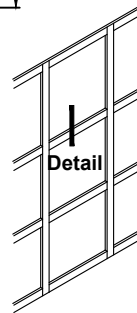
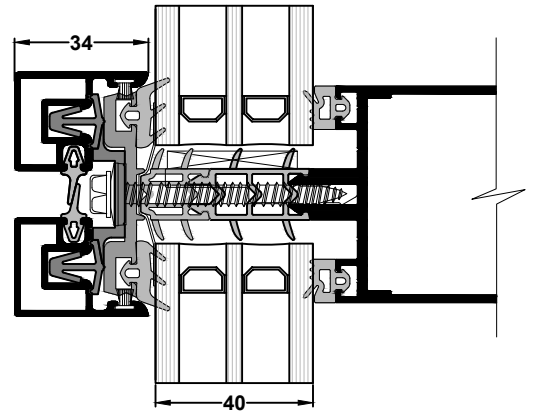
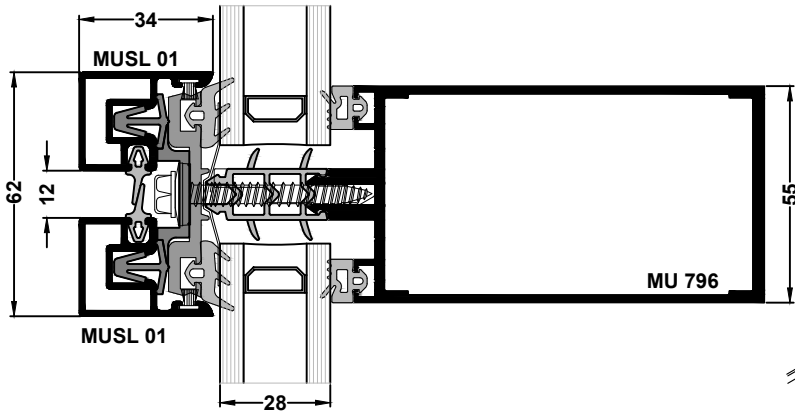

MU 800Hi - CAPPED CURTAIN WALL SYSTEM

Matrix capping details

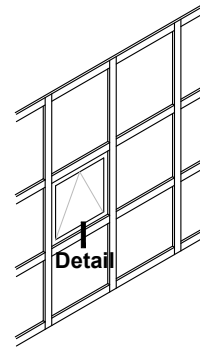
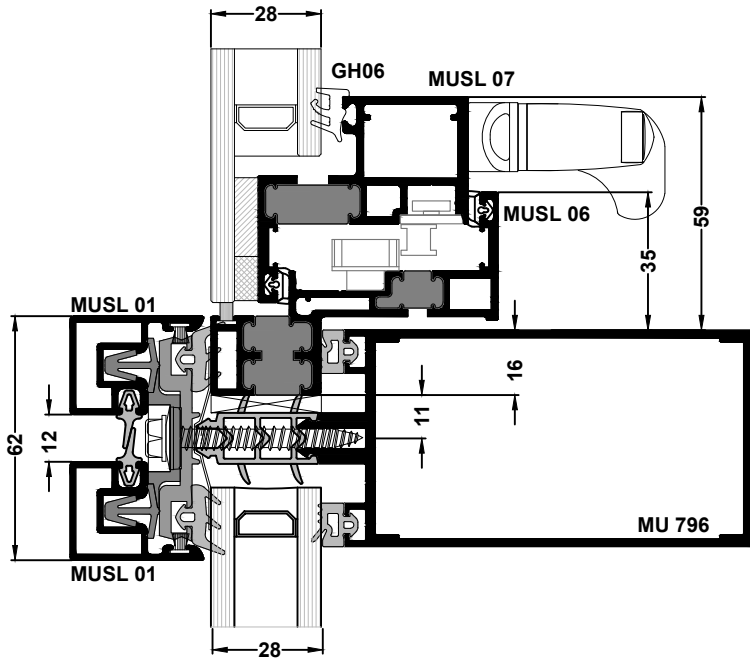

Packing detail as shown on page 1.4.17

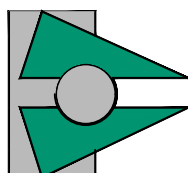
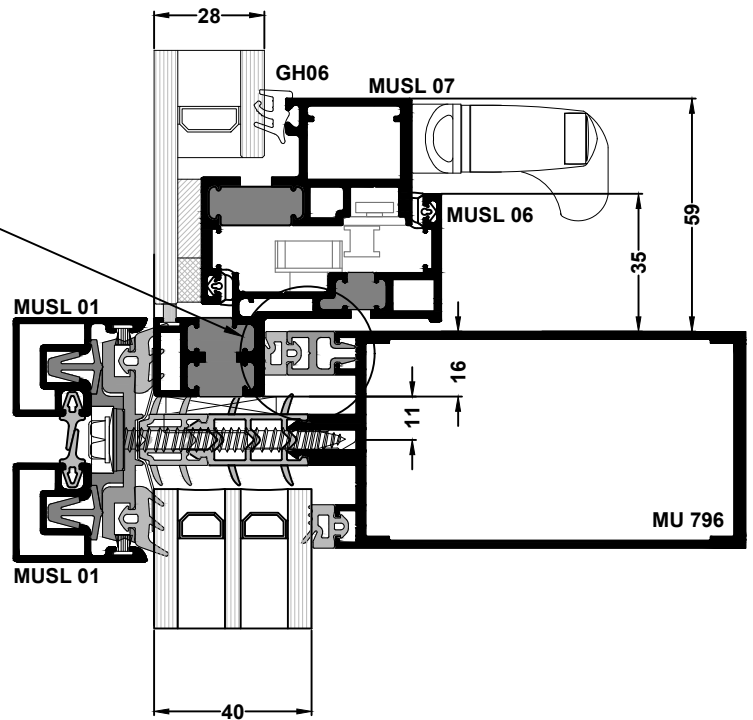
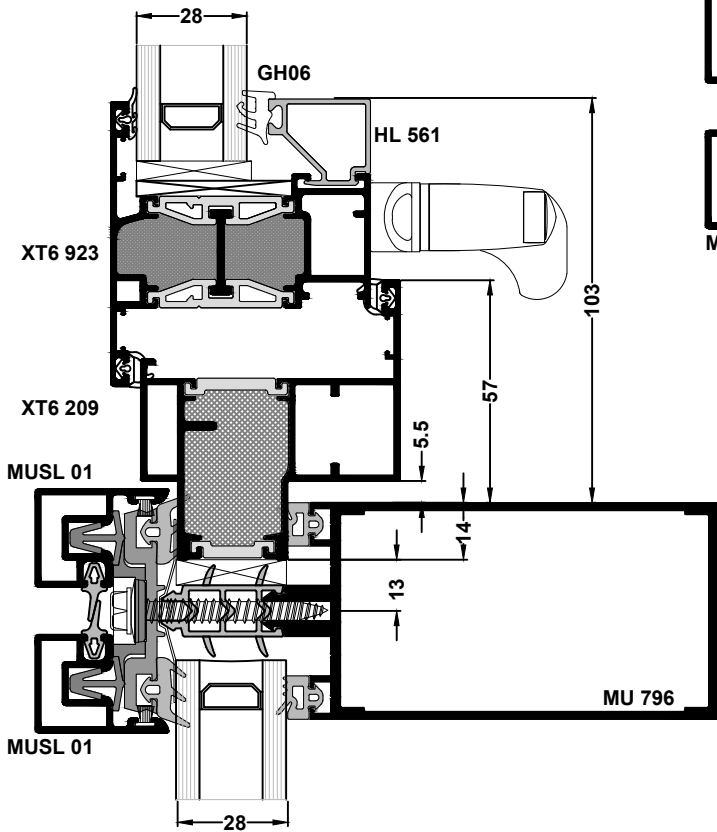

MU 800Hi - CAPPED CURTAIN WALL SYSTEM

Matrix capping details

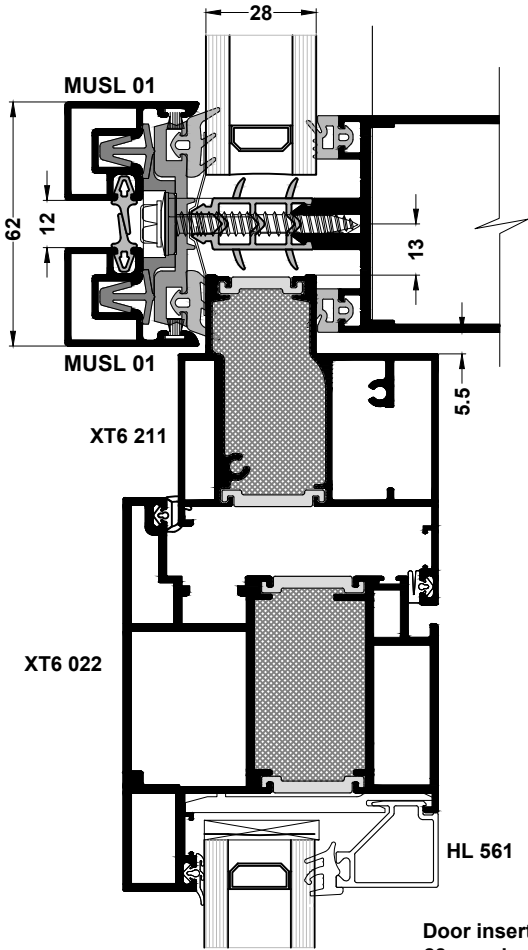

Door insert: Open out (XT6022)
28mm glazing

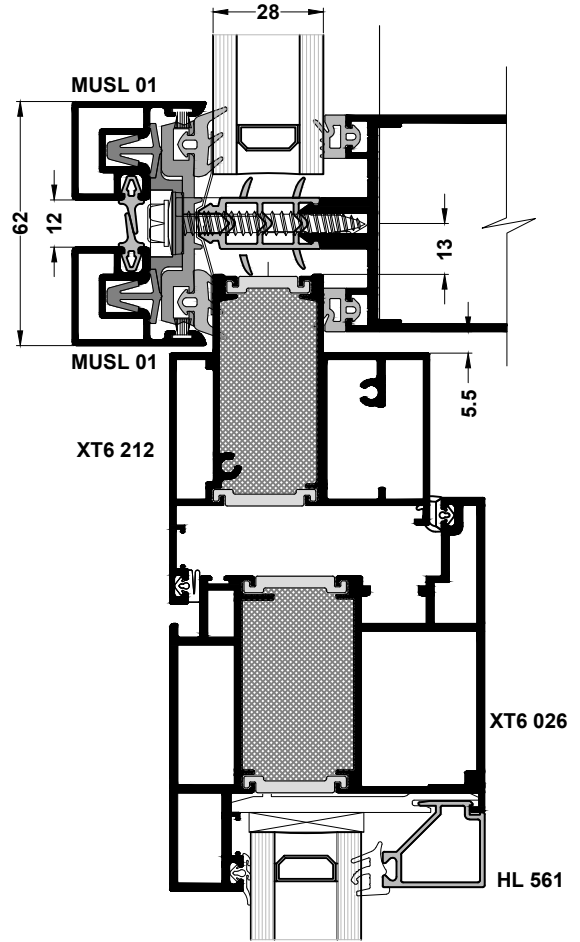

Door insert: Open in (XT6026)
28mm glazing

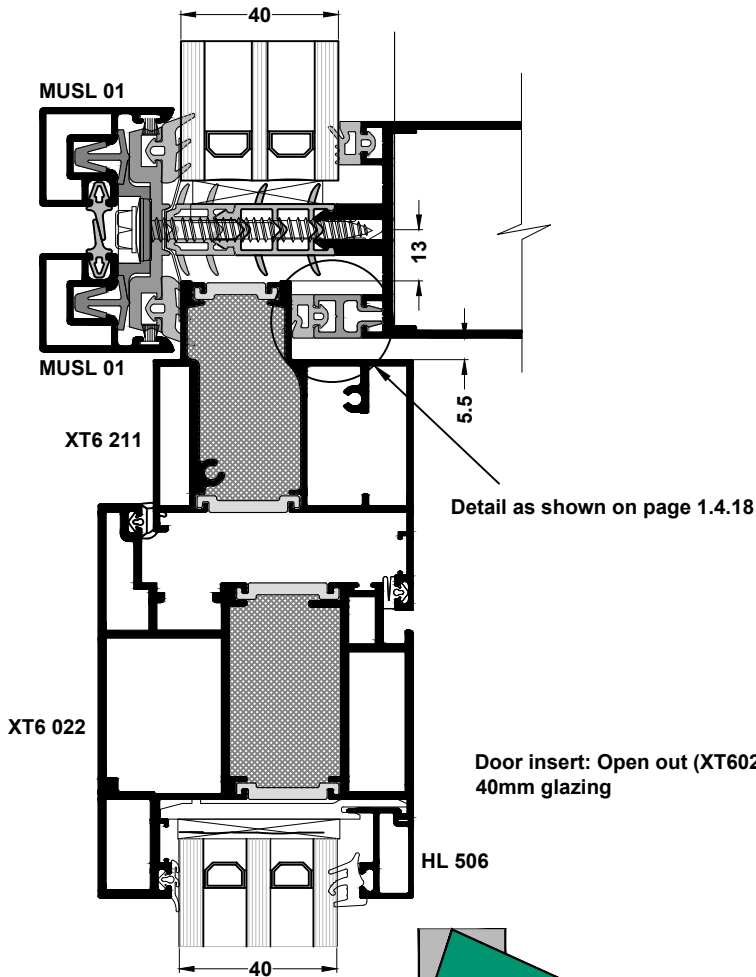

Detail as shown on page 1.4.18

Door insert: Open out (XT6022)
40mm glazing

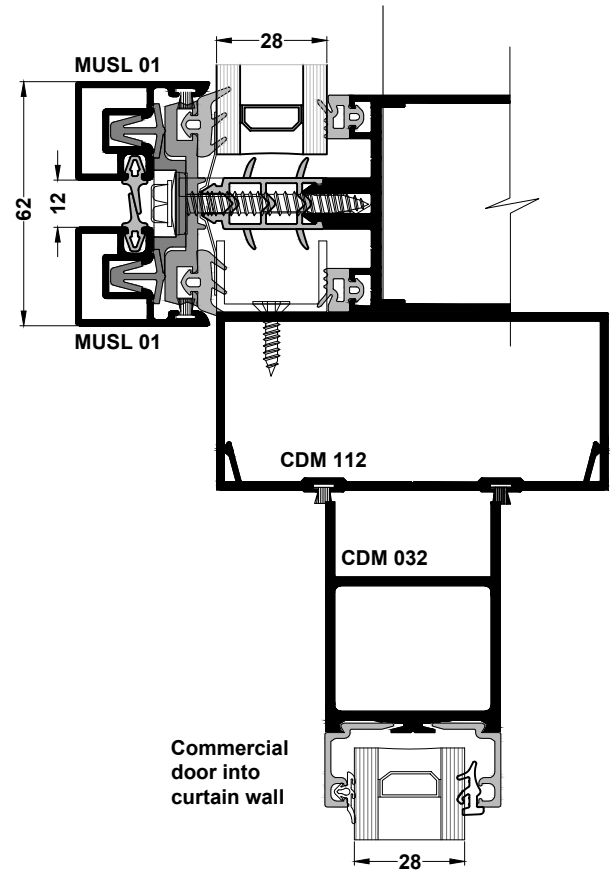

Commercial door into curtain wall

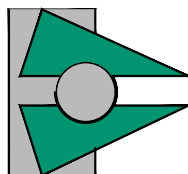

MU 800Hi - CAPPED CURTAIN WALL SYSTEM

Matrix capping details

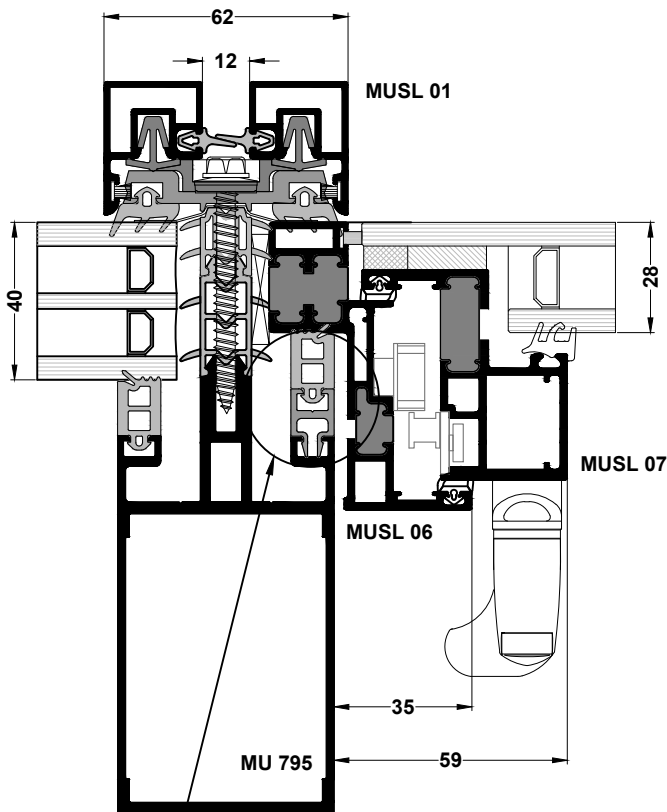
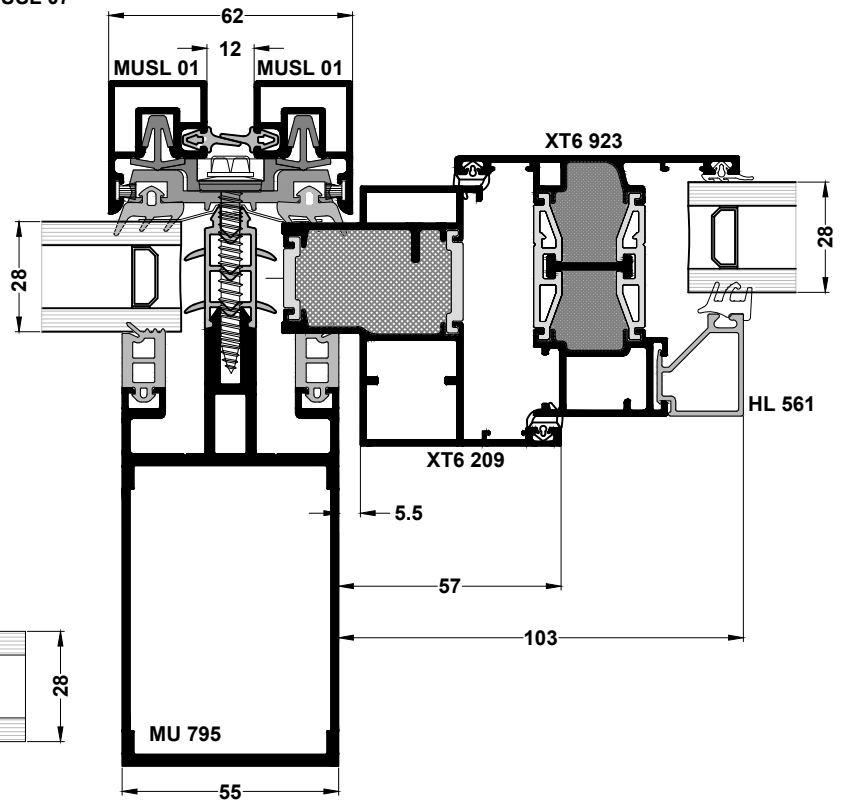
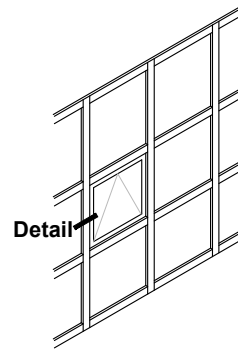
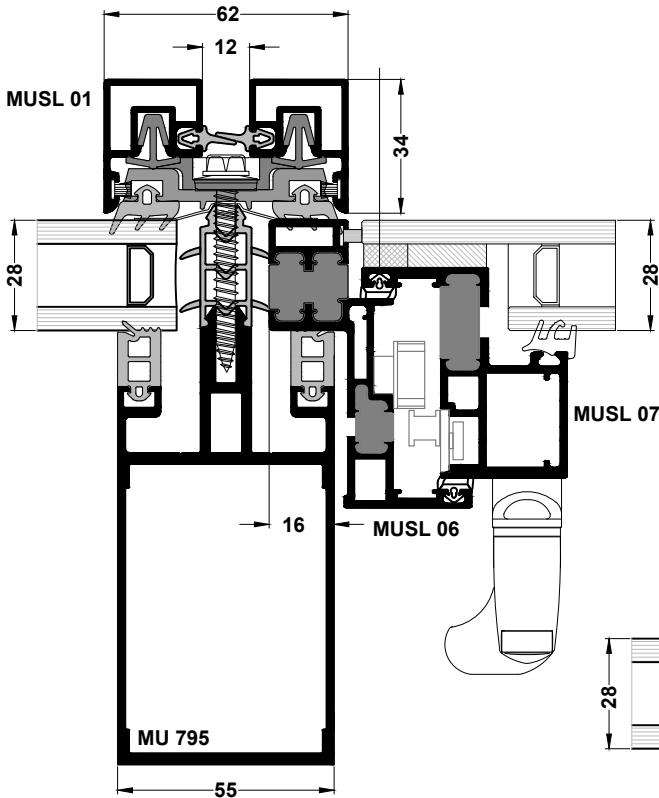

Packing detail as shown on page 1.4.17

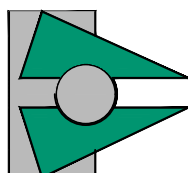

MU 800Hi - CAPPED CURTAIN WALL SYSTEM

Facetted Curtain Wall

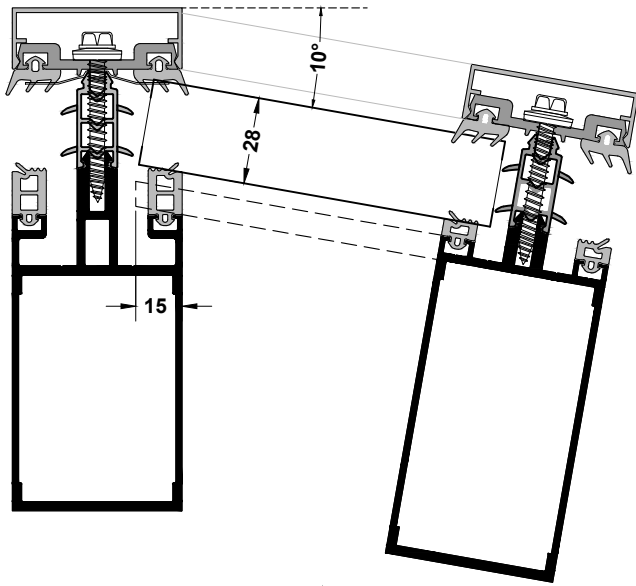

Note :

Maximum angle for facetted screens depends on the glazing thickness.

