

APA Facade TB50 / Facade TB50 SG Curtain Wall Suite Technical Specification

**APA
SYSTEMS**

www.apasystems.co.uk ~ www.apasystems.ie

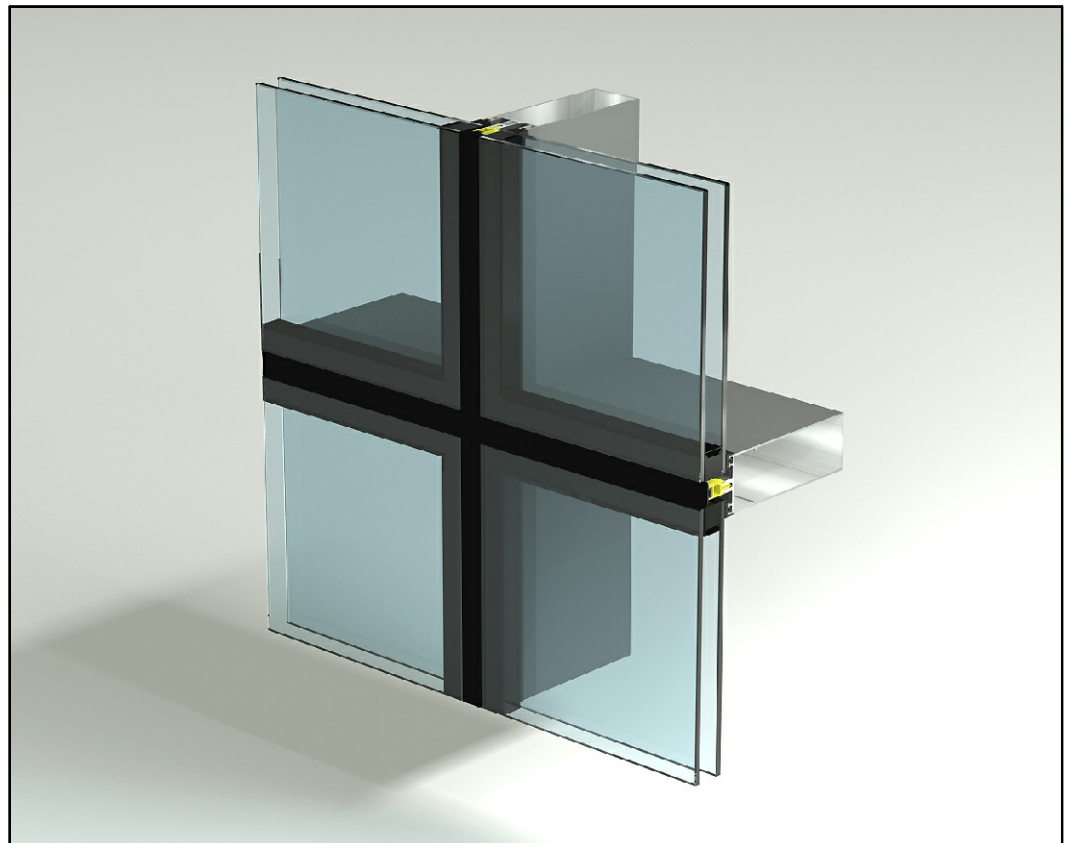
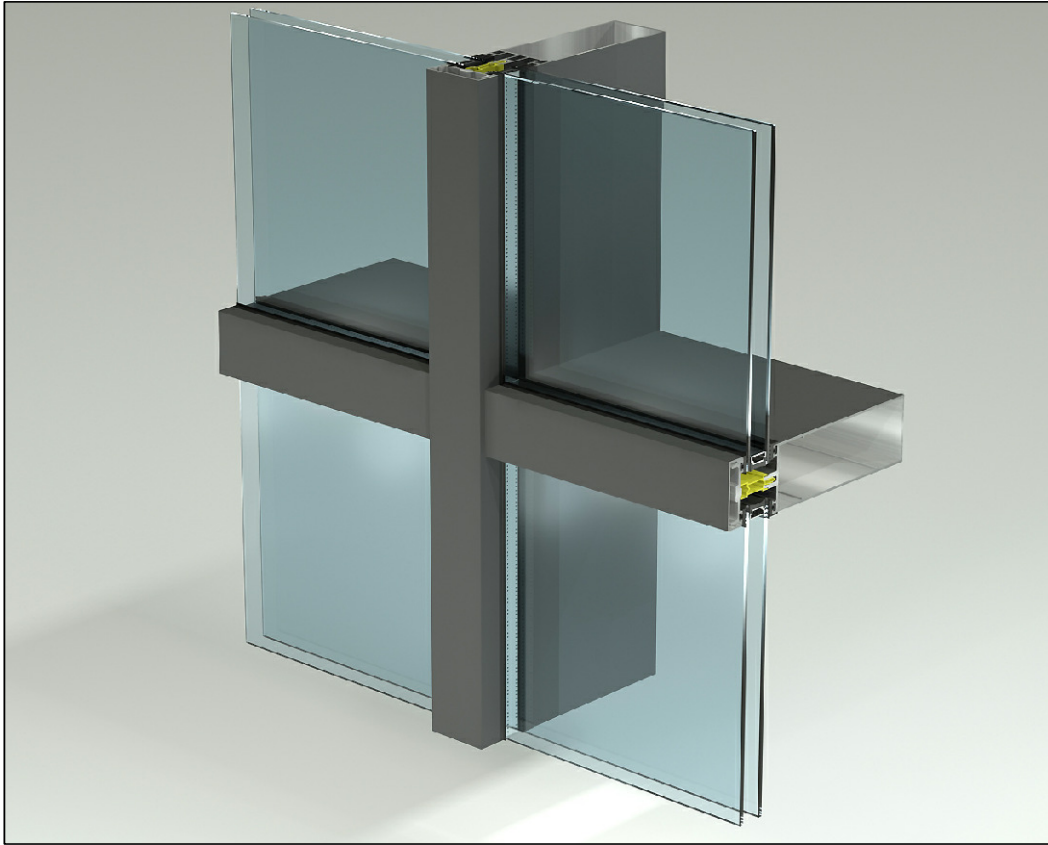

FACADE TB50

STANDARD COVER CAP
& PRESSURE PLATE

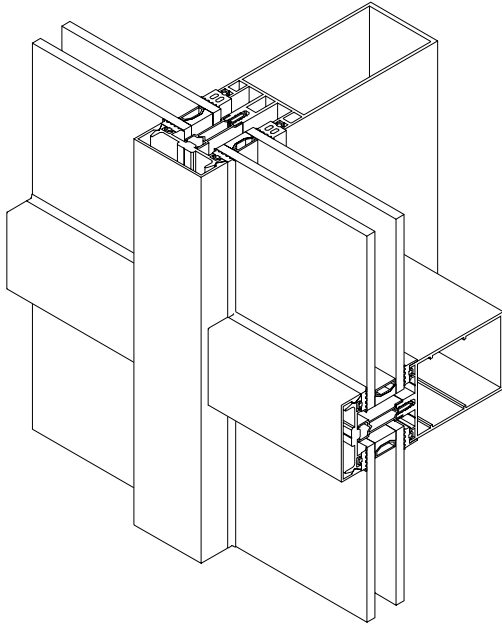

FACADE TB50

AEROFOIL VERTICAL COVER CAP
& PRESSURE PLATE

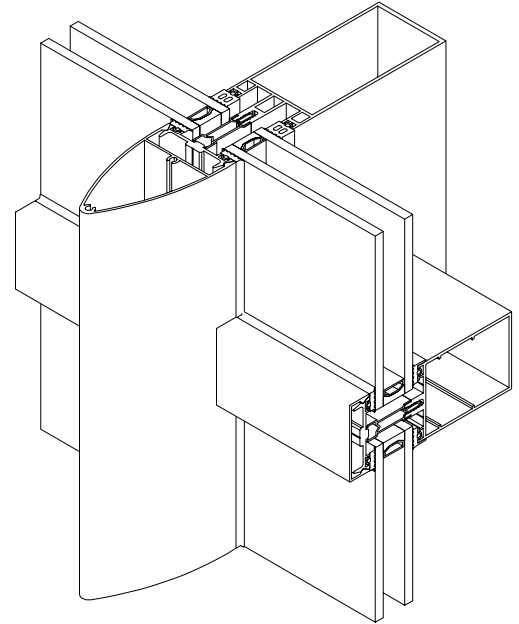

OVER VIEW
Facade TB50

- Slight line 50mm
- Stick construction.
- Mullion range from 50mm to 275mm
- Transom range from 50 mm to 195mm
- Glazing insert range up to 50mm
- Mullion Drained & Pressure equalized
- Mullion to Transom Joint: Overlap dry fixed technology
- Uf Values range between 1.2 - 2.4w/m²K - In accordance with EN 12412-2 & EN 10077-2

FACADE TB50

PF COVER CAP
& PRESSURE PLATE

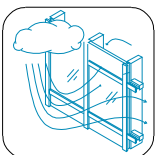
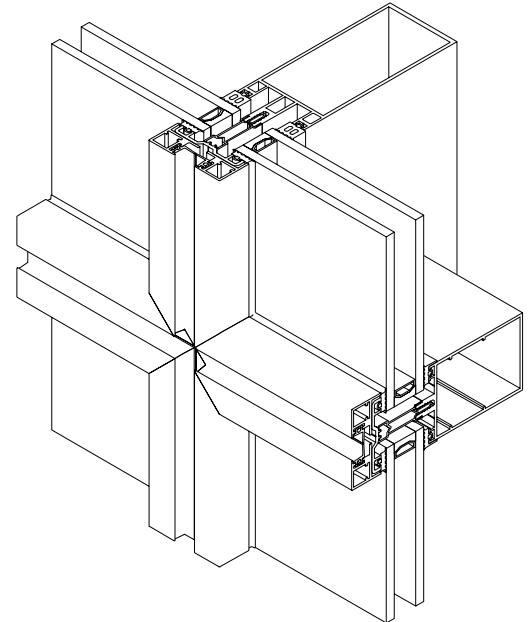

Air permeability:
600Pa

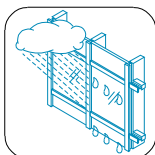

Watertightness:
1200Pa

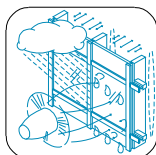

Watertightness:
Dynamic 900Pa

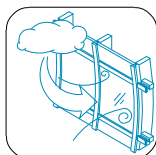

Wind resistance:
2400Pa

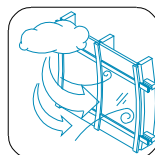

Safety: 3600Pa

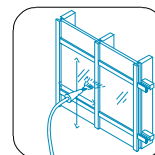

Hose test: AAMA

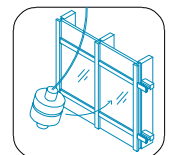

Impact test: 500Nm

DATE: 10/03/2015	REVISION: 0	TITLE: System Variants	SYSTEM: Facade TB50 - Curtain Wall	A4	5A.00.A.01
---------------------	----------------	---------------------------	---------------------------------------	-----------	------------

FACADE TB50

IM MULLION & 'H' Channel COVER
 CAP & PRESSURE PLATE

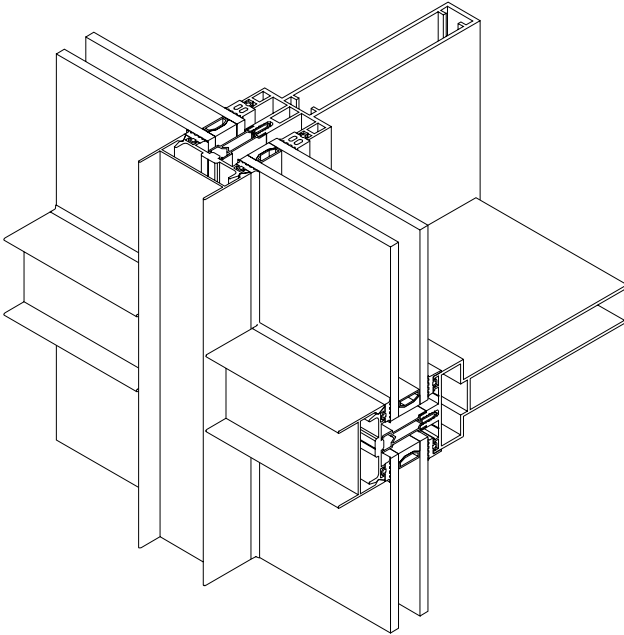

FACADE TB50

'T' (Low protruding) COVER CAP
 & PRESSURE PLATE

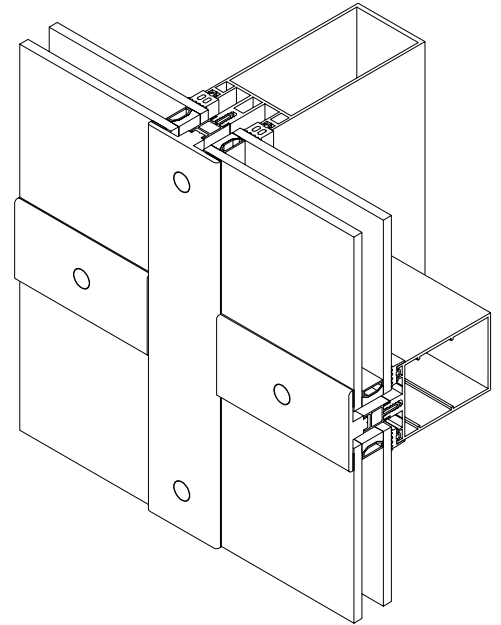

FACADE TB50

'H' Channel COVER CAP
 & PRESSURE PLATE

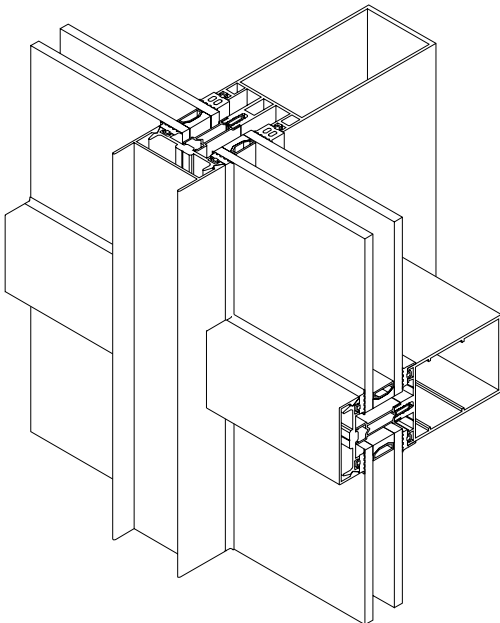

FACADE TB50

125C COVER CAP
 & PRESSURE PLATE

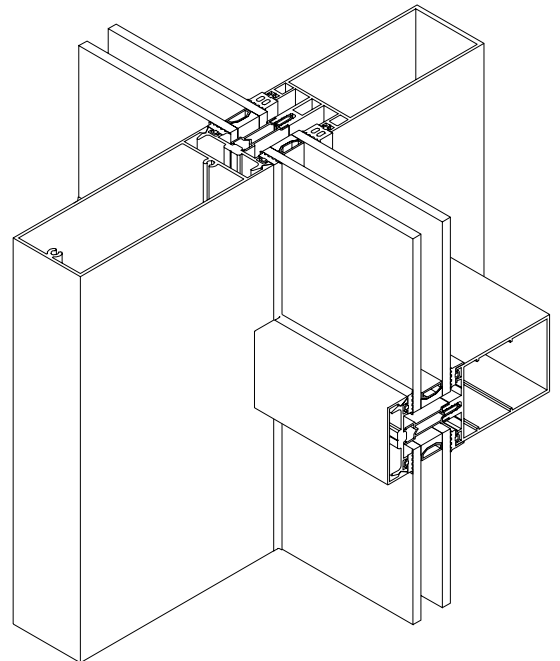

DATE: 10/03/2015	REVISION: 0	TITLE: System Variants	SYSTEM: Facade TB50 - Curtain Wall	A4	5A.00.A.02
---------------------	----------------	---------------------------	---------------------------------------	-----------	------------

FACADE TB50 SG

VERTICAL & HORIZONTAL SILICONE JOINT

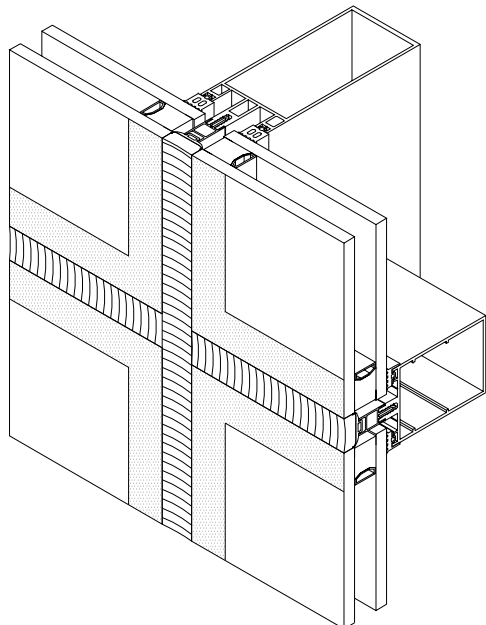

FACADE TB50 SG

VERTICAL SILICONE JOINT
HORIZONTAL AEROFOIL COVER CAP

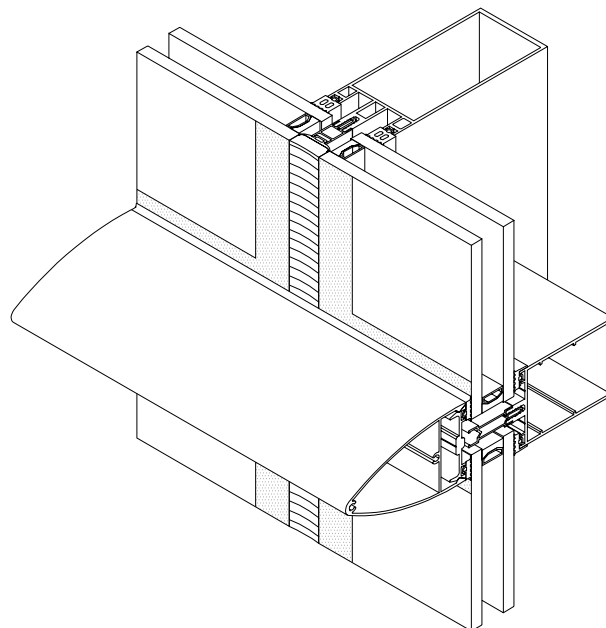

OVER VIEW
Facade TB50 SG

- Slight line 25/22/25
- Stick construction.
- Mullion range from 50mm to 275mm
- Transom range from 50 mm to 195mm
- Glazing insert range up to 42mm
- Mullion Drained & Pressure equalized
- Mullion to Transom Joint: Overlap dry fixed technology
- Uf Values range between 1.2 - 2.4w/m²K - In accordance with EN 12412-2 & EN 10077-2

FACADE TB50 SG

HORIZONTAL SILICONE JOINT
20mm VERTICAL COVER CAP

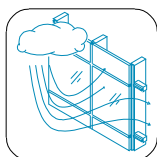
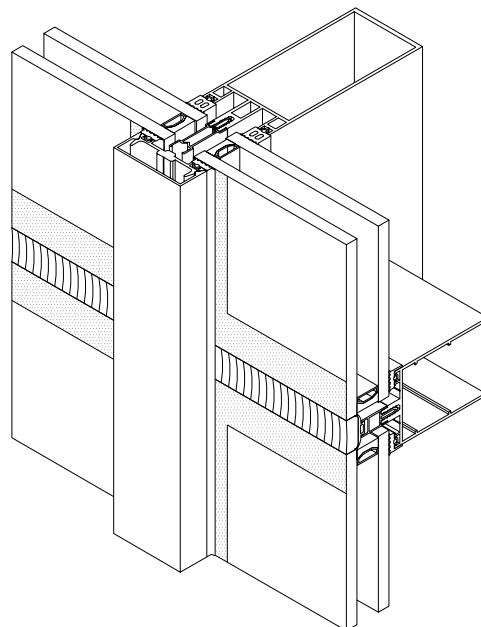

Air permeability:
600Pa

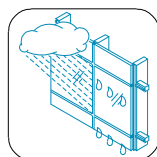

Watertightness:
1200Pa

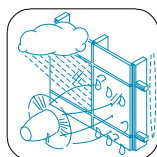

Watertightness:
Dynamic 900Pa

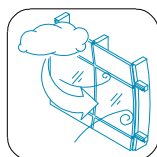

Wind resistance:
2400Pa

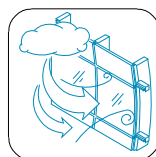

Safety: 3600Pa

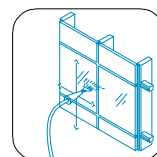

Hose test: AAMA

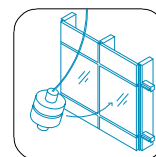

Impact test: 500Nm

DATE: 10/03/2015	REVISION: 0	TITLE: System Variants	SYSTEM: Facade TB50 - Curtain Wall	A4	5A.00.A.03
---------------------	----------------	---------------------------	---------------------------------------	-----------	------------

Scope

SYSTEM SPECIFICATIONS FOR THE FAÇADE TB50 & FAÇADE TB50 SG

The Façade TB50 / TB50SG by APA Systems is extruded from alloy 6063T6 to BS1474.

The Façade TB50 / TB50SG mullions and transoms dimension should be of the required depth to meet with the max specified design load. BS 6399 Part 2 should be used to ascertain the wind loads applicable to the given location.

General sight line of 50mm. A range of facets and glazing plane are catered for within the systems using gaskets and extruded angular capping. See variants, multiple combinations not shown are also possible, please contact the technical department.

The glazing infill is retained in place with the use of an extruded pressure plate with the heads of the screws being covered with an extruded clip on capping. The Façade TB50 contains a range of Cover caps that are fully integrated leading to multiple external visual design options.

The façade TB50 / TB50SG system is drained and ventilated with facilities for zone drainage and pressure equalization using an injection moulded dam piece or gargyle.

The façade TB50 / TB50SG transom mullion junctions are formed with an overlap joint where the transoms are notched to allow them fit on to the mullion gasket channel and are then fixed to same using a proprietary screw. This joint is sealed by means of a preformed EPDM piece to prevent any capillary action, water ingress or noise from movement.

All the fixings and screws which are to be incorporated into the façade are stainless steel to a grade suitable for the location (i.e. All exposed fixings to the exterior are to be grade 316 stainless steel)

The chosen contractor is to be an approved APA Systems Installer with all the participating office and site staff being fully trained in the correct use of the specified system

FINISH SPECIFICATIONS FOR THE FAÇADE TB50

The profiles and sections are polyester powder coated to the "Qualicoat Approved standard" using the ALESTA® AP, paint system. Up to a 25 year guarantee can be obtained on polyester powder coating. (It is noted that certain conditions may reduce this period i.e. proximity to the sea or local pollutants etc application must be made for the warrantee if any of these conditions exist)

Polyester Powder Coating

Powder coating conforming to BS EN 12206-1:2004: 'Paints and varnishes - Coating of aluminium and aluminium alloys for architectural purposes'

Polyester Powder coating ALESTA® AP applied by a Qualicoat approved applicator using a standard RAL colour in matt finish to EN12206-1 (2004). Prior to the application of the polyester power coating the aluminium profiles are pretreated using an 10-stage process of acid etching, chromate primer and water rinsing. A guarantee of 25 years must be applied for in advance of starting the project on site. It is noted that this period of time is subject to the location or proximity to a marine environment.

PROJECT SPECIFICATION

Project specification in NBS format are available from APA Systems on request.

DATE: 01/04/2015	REVISION: A	TITLE: Introduction	SYSTEM: Facade TB50 - Curtain Wall	A4	5A.01.A.01
---------------------	----------------	------------------------	---------------------------------------	-----------	------------

PERFORMANCE SPECIFICATIONS FOR THE FAÇADE TB50 / TB50SG

The Façade TB50 system meets with the criteria of the CE marking for Curtain Wall as published by FAECF in cooperation with the EEA which was mandatory from December 1st 2005
 The system has being fully tested using the following standards

- BS EN 12152
- BS EN 12153
- BS EN 12154
- BS EN 12155
- BS EN 12179
- BS EN 13116
- DD ENV 13050
- BS EN 13830
- CWCT Test method for curtain walls (Part 8 Sequence B)

The sample tested 6m (wide) x 6m (high) was of adequate size to meet with the requirements of the CWCT and the CE mark and to meet or exceed the following test pressures

Air permeability	600 pa
Water static pressure	1200pa
Wind Resistance	2400pa
Water Dynamic CWCT	900pa
Water hose	AAMA
Safety	3600pa

A full copy of the test report is available on request.

Technical Report - **Report Number: DPP/R14282-2**



DATE: 10/03/2015	REVISION: 0	TITLE: Introduction	SYSTEM: Facade TB50 - Curtain Wall	A4	5A.01.A.02
---------------------	----------------	------------------------	---------------------------------------	-----------	------------

CE MARKING

What is CE Marking?

A CE Mark is a mandatory conformity marking for products placed on the market in the European Economic Area (EEA). A CE Marking indicates to a customer that a product conforms to specific European technical standards, known as harmonised European Norms (hEN).

Do I need to CE Mark my facade?

Yes. From 1 July 2013 it is mandatory for manufacturers of construction products, including Façades, windows and doors, to apply a CE Marking to the products.

This requirement is part of the Construction Products Regulation 2011 (CPR), which replaces the Construction Products Directive (CPD).

Who is responsible for CE Marking?

Under Construction Products Regulation, the manufacturer* of a product must apply the CE Marking. The 'manufacturer' is classed as the company or individual that creates the finished 'construction element'. In the cases of facades, windows and doors, this means the person who supplies and installs the finished product.

From 1 July 2013, therefore, all fabricators will need to apply CE Markings to their products. Failure to do so will be a criminal offence.

Why is CE Marking becoming mandatory?

The aim of Construction Products Regulation is to harmonise compliance with European standard EN 14351-1 across the EU.

What do I need to do?

To comply with the new rules, you will need to: Add a CE Mark to every façade, window or door you manufacture

Provide a Declaration of Performance (DoP) with each product as proof that it meets the required standards

The Declaration of Performance can either be provided to the customer as a paper copy, or electronically on a website. Each Declaration of Performance must have a unique number which corresponds to the CE Mark applied to each Façade, window and door.

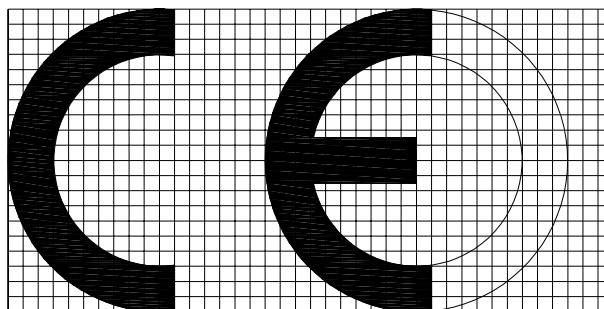

DATE: 10/03/2015	REVISION: 0	TITLE: Introduction	SYSTEM: Facade TB50 - Curtain Wall	A4	5A.01.A.03
---------------------	----------------	------------------------	---------------------------------------	-----------	------------

GLASS AND GLAZING

Suggested Glazing spec to accompany the façade TB50 system:

Frames shall be glazed in accordance with the recommendations given in BS 6262.

28mm double glazed units, soft coat low "E" 90% argon filled glazing units.

Safety glass to be in accordance with BS 6262 & BS 6201- Glass in Buildings.

All glazing must be installed in accordance with BS 6262 and the double glazed unit manufacturer's and system supplier's instructions.

To comply with BS 5713, hermetically sealed and Kite mark certified.

All frames shall contain sealed units, which shall be manufactured in accordance with EN1279 Parts 2 and 3 and carry the necessary and appropriate guarantee.

Glazing System: All double-glazed units, panels and inserts shall be supported by use of support blocks. All units shall be dry glazed using external extruded pressure plate captive gaskets externally and captive gasket internally. The internal mullion and transom gaskets are to be accurately jointed in each corner and bed in a flexible EPDM sealant. Setting blocks and location pieces shall be fitted in accordance with BS 6262 in order to ensure the windows are maintained square and rigid.

INSTALLATION RECOMMENDATIONS

The installation of facades and façade elements is one of the more complex site operations. It requires a range of skills and knowledge yet has not been recognised as a particular skill or trade. Façade failure, particularly water leakage, is the most common cause of failure in new buildings.

The CWCT Curtain Wall Installation handbook brings together advice on installation of Curtain Wall including all the major components: frames, gaskets, sealants, finishes, glass and fixings. It is based on experience gained by CWCT in setting up training centres for installers and in training main contractors' site supervisors.

The book explains why things should be done and highlights those things that are most critical to the success of curtain wall and window installation.

This handbook is a guide to achieving better curtain wall installation.

Full details of CWCT's training programme are available at <http://www.cwct.co.uk/installers>.

DATE: 10/03/2015	REVISION: 0	TITLE: Introduction	SYSTEM: Facade TB50 - Curtain Wall	A4	5A.01.A.04
---------------------	----------------	------------------------	---------------------------------------	-----------	------------

ESTIMATE / SOFTWARE - LOGIKAL®

Input of Elements

The easy-to-understand program control in APA-LogiKal® makes it possible for any user to find their way around the software. It's easy to use element input to create windows, doors, facades, shop front items, sliding doors glazed walls of nearly any type and size. You can define the properties of each element step by step. The software leads you through the entire design process and ensures that not a single detail is forgotten.

Estimating

Based on your input, the purchase terms you've defined and the manufacturer's pricing information stored in the database, APA-LogiKal® calculates the purchase costs for your project. The overhead supplements and labour costs entered are then used to calculate and present the complete costs of construction.

Structural Analysis

You can use the static analysis module to adapt the parameters for a static calculation to existing conditions as specified by EN 1991-1-4. Many countries' standards are already provided in the APA-LogiKal® database. Wind loads can optionally be entered manually or automatically calculated by APA-LogiKal®. Depending on country-specific standards you can choose between different wind zones with their associated terrain categories.

Cut Optimization

All cut lengths, in an order, are distributed between bars in such a way that the smallest possible wastage is obtained. A graphic shows the orientation of the profile on the saw and the order of the individual lengths to be cut. Residual lengths from stock can also be used. The program calculates the most optimal fixed lengths. Different length ranges can be set to different fixed lengths so that multiple fixed lengths per profile are possible. Every profile is assigned a barcode that can be printed on adhesive labels. If your order includes profiles separated into skins and isolators, a connection list will be appended to the printout.

Further Information

Additional information regarding APA products can be found by registering for the download centre on the following website.

www.apasystems.ie

Ireland

APA systems Ltd
Unit 12 Parkmore Industrial estate Longmine Road
Dublin 12
Ireland

Telephone +353(1) 4509102

Fax + 353 (1) 4501557

Email info@apasystems.ie

Internet www.apasystems.ie

www.apasystems.co.uk

United Kingdom

APA Systems Ltd
Block 3
City west Office Park
Gelder Road
Leeds
West Yorkshire
LS12 6LX
Telephone + 44 (0) 113 251 2191
Email: info@apasystems.co.uk
Internet: www.apasystems.co.uk

DATE: 10/03/2015	REVISION: 0	TITLE: Introduction	SYSTEM: Facade TB50 - Curtain Wall	A4	5A.01.A.05
---------------------	----------------	------------------------	---------------------------------------	-----------	------------

Facade TB50 - Curtain Wall - Certificate of Testing

In accordance with 'Standard for systemised building envelopes' CWCT, 2006

Air permeability: _____ PASS

Pressure: _____ 600Pa (infiltration and exfiltration)

Leakage rate (max): _____ 0.18mm³/hour/m² - infiltration 0.22mm³/hour/m² exfiltration

Average of 0.2m³/hour/m²

Watertightness - static: _____ PASS

Test pressure: _____ 1200Pa

Watertightness - dynamic: _____ PASS

(Dynamic aero engine @ 900Pa)

Wind resistance

Serviceability: _____ PASS

Test pressure: _____ 2400Pa

Wind resistance

Safety: _____ PASS

Test pressure: _____ 3600Pa

Hose test: _____ PASS

Impact test: _____ PASS

Drop height: _____ 950mm

Impact energy: _____ 500Nm

Impact tests carried out in accordance with

BS EN 14019 at all specified locations. _____ No damage observed.

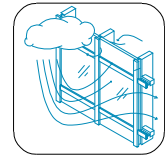

Air permeability:
600Pa

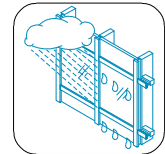

Watertightness:
1200Pa

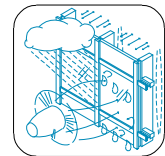

Watertightness:
Dynamic 900Pa

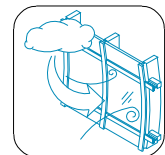

Wind resistance:
2400Pa

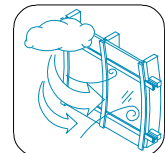

Safety: 3600Pa

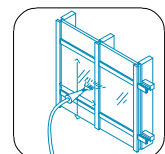

Hose test: AAMA

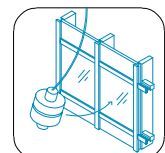

Impact test: 500Nm

Test sequence and reports have being carried out by an independent UKAS accredited test center.

Report Number: DPP/R14282-2 - (Hard copy Available on request)

DATE: 10/03/2015	REVISION: A	TITLE: Introduction	SYSTEM: Facade TB50 - Curtain Wall	NTS	A4	5A.01.A.06
---------------------	----------------	------------------------	---------------------------------------	-----	-----------	------------

Facade TB50SG - Curtain Wall - Certificate of Testing

In accordance with 'Standard for systemised building envelopes' CWCT, 2006

Air permeability: _____ PASS

Pressure: _____ 600Pa (infiltration and exfiltration)

Leakage rate (max): _____ 0.18m³/hour/m² infiltration
 _____ 0.22m³/hour/m² exfiltration

Watertightness - static: _____ PASS

Test pressure: _____ 1200Pa

Watertightness - dynamic: _____ PASS

(Dynamic aero engine @ 900Pa)

Wind resistance

Serviceability: _____ PASS

Test pressure: _____ 2400Pa

Wind resistance

Safety: _____ PASS

Test pressure: _____ 3600Pa

Hose test: _____ PASS

Impact test: _____ PASS

Drop height: _____ 950mm

Impact energy: _____ 500Nm

Impact tests carried out in accordance with

BS EN 14019 at all specified locations. _____ No damage observed.

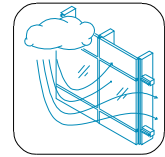

Air permeability:
600Pa

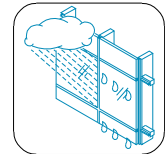

Watertightness:
1200Pa

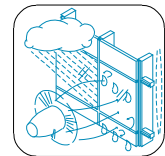

Watertightness:
Dynamic 900Pa

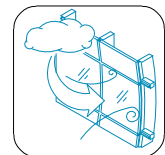

Wind resistance:
2400Pa

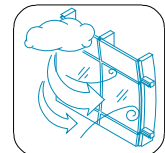

Safety: 3600Pa

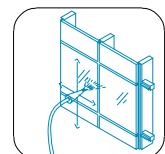

Hose test: AAMA

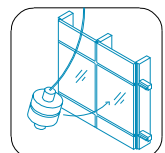

Impact test: 500Nm

Test sequence and reports have being carried out by an independent UKAS accredited test center.

Report Number: DPP/R14282-2 - (Hard copy Available on request)

DATE: 10/03/2015	REVISION: A	TITLE: Introduction	SYSTEM: Facade TB50 - Curtain Wall	NTS	A4	5A.01.A.07
---------------------	----------------	------------------------	---------------------------------------	-----	-----------	------------

STATIC PERFORMANCE

Mullions

Curtain wall mullions span from subfloor to subfloor fixed by anchoring points. As a general rule the anchoring should be longitudinally free in one direction, i.e. one live one dead. Thus ensuring that the vertical forces produce elongating or expansion of the profile, never compression.

The mullion is mainly subjected to the horizontal pressure of the wind, uniformly distributed along its length, and the vertical forces of its own weight and the load of the glass / inserts.

The maximum allowable deflection should not exceed $L/200$, or 15mm for the 1st 6mtrs & $L/300$ thereafter.

The designer should confirm that the total stress applied to the aluminium section is less than the permitted stress in the aluminium. These values are set out in the standards.

A trapezoidal wind loading distribution across the panel may be assumed, where a portion of the wind load is resisted by the transom (and transferred to the mullions as point loads)

Transoms

Curtain wall transom span horizontally between mullion. They are fixed to the mullion by means of overlap joint screw fixed & supported by shear blocks. The transom is subject to forces in both the frontal and vertical plane. Similar to curtain wall mullions the transoms are subjected to the horizontal pressure of the wind, and the designer should confirm that total stress applied to the aluminium section is less than the permitted stress in the aluminium, (6063-T6).

The maximum allowable frontal deflection should not exceed $L/200$, or 15mm.

The maximum allowable vertical deflection should not exceed $L/500$, or 3mm.

Single Span - Mullion
 Example of wind loading onto a trapezoidal surface.

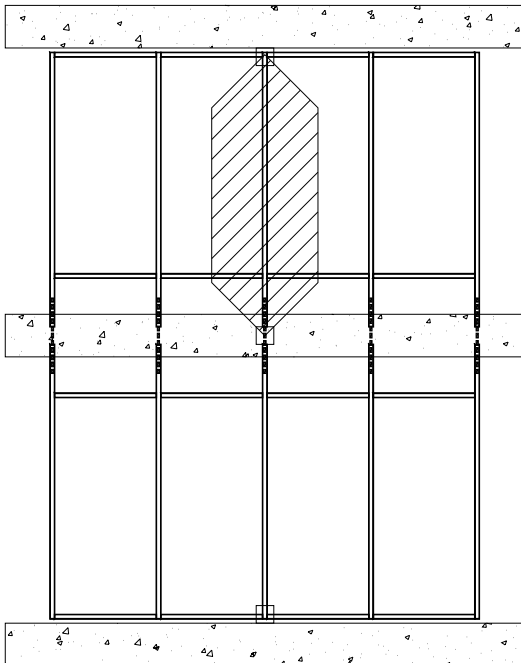

Example
 Curtain Wall
 standing from
 the slab.
 Single Span

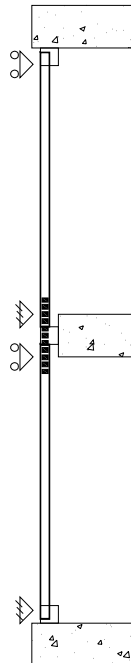

Example
 Curtain Wall
 Hung from
 the slab.
 Single Span

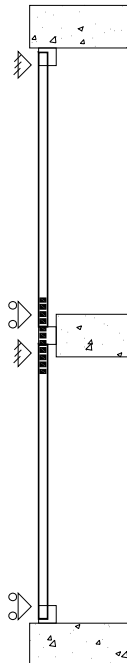

Transom
 Example of wind loading onto a trapezoidal surface.

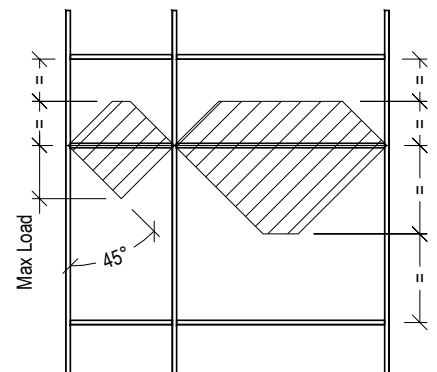

DATE: 10/03/2015	REVISION: 0	TITLE: Introduction	SYSTEM: Facade TB50 - Curtain Wall	1:1	A4	5A.01.A.08
---------------------	----------------	------------------------	---------------------------------------	-----	-----------	------------

PERFORMANCE REQUIREMENTS FOR CURTAIN WALL BRACKETS

Introduction

Brackets form the link between the curtain wall and the structure. They are of critical importance to the safety and serviceability of the curtain wall and also have a profound effect on its buildability. Bracket design is normally undertaken by the system fabricator.

Performance criteria

Brackets for fixing Curtain Wall are required to fulfil some or all of the following functions:

- Transfer loads from the curtain wall to the structure;
- Accommodate induced deviations (tolerances);
- Accommodate inherent deviations (movements);
- Resist corrosion;
- Resist fire;

Vertical forces due to dead loads and horizontal forces due to live loads are transferred to the structure by the brackets.

☞ Dead load

The precise weight of the cladding will be determined as the design is developed, but early estimates need to be realistic to prevent lengthy re-design of the support members. This requires a knowledge of the type of cladding system, materials, wind load and grid dimensions. The curtain wall is normally supported in front of the supporting structure with a buffer zone to accommodate tolerances. The line of action of the load will therefore be in front of that of the support and bending and/or torsional stresses will be induced in the connecting bracket.

☞ Live load

Wind loads in the form of negative (suction) or positive pressures are usually the dominant load case, with negative pressures at, for example, corners twice the magnitude of positive pressure at the centre of the windward face. Wind loads are determined by the site location and surrounding terrain, the shape of the building, local effects (e.g. sharp corners) and the size and location of openings.

To transfer these loads two types of fixings are required:

Support fixings are required to carry dead loads and these fixings will prevent vertical movement of the mullion relative to the supporting structure.

Only one dead load fixing is necessary for each length of mullion and provision of additional support fixings is undesirable as movement will be restricted (see discussion of inherent & deviations below).

Restraint fixings are required at both top and bottom of mullions to resist wind loads.

Induced deviations

Deviations are differences between specified nominal dimensions and the actual measured dimensions. Induced deviations are permanent deviations, which arise due to variations and errors in the manufacturing and construction process.

Tolerances are agreed limits to these deviations, which the design should be able to accommodate.

Inherent deviations

Inherent deviations are changes in dimensions arising as a result of inherent material properties. They may be permanent or reversible and include:

- Deflections due to applied loads;
- Thermal movements;
- Shrinkage;
- Moisture movement;
- Creep;
- Settlement.

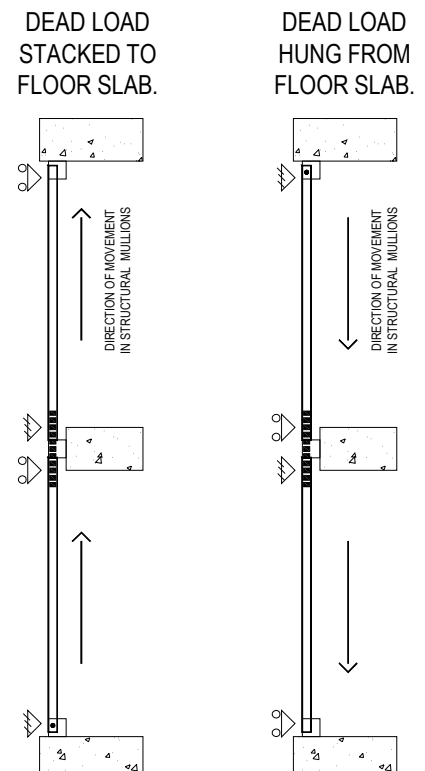

DATE: 10/03/2015	REVISION: 0	TITLE: Introduction	SYSTEM: Facade TB50 - Curtain Wall	1:1	A4	5A.01.A.09
---------------------	----------------	------------------------	---------------------------------------	-----	-----------	------------

STRUCTURAL MOVEMENT

Horizontal racking

In a stick wall racking of the frame to accommodate wind or seismic shear is possible until the edge clearance is reduced to zero. The façade TB50 has an edge clearance of 5mm (this includes a safety clearance of 2mm). Note the façade TB50SG has a reduced edge clearance of 4mm.

Vertical racking

Floor deflections will also give rise to racking of a stick curtain wall frame. In this case the mullions move, while remaining vertical, causing the transoms to rotate. In a stick wall racking of the frame to accommodate floor deflections or settlement is possible until the edge clearance is reduced to zero. The façade TB50 has an edge clearance of 5mm (this includes a safety clearance of 2mm) Note the façade TB50SG has a reduced edge clearance of 4mm.

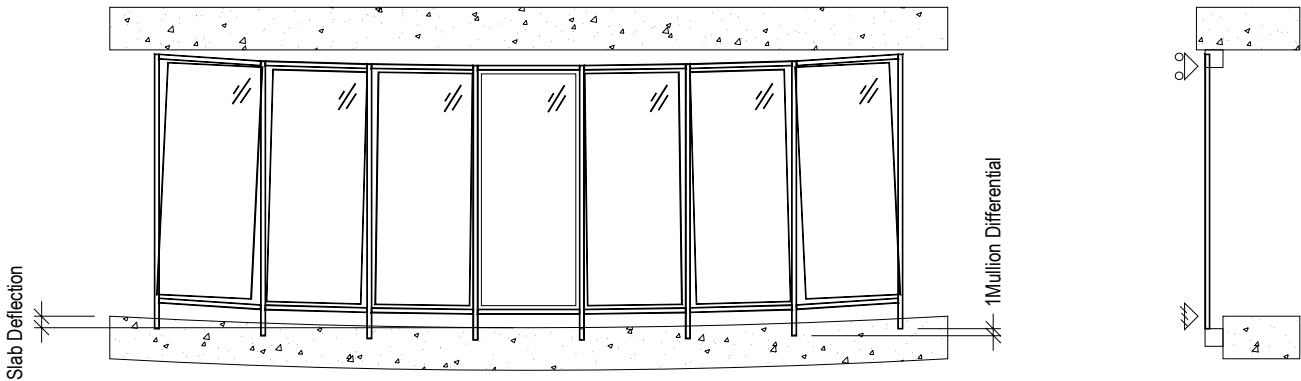

Note edge clearance around the glass has to accommodate all of the following movement.

- Relevant slab edge deflections
- Structural sway
- Column shortening
- Thermal expansion and contraction.

It also has to accommodate tolerances due to:

- Glass manufacture
- Façade fabrication
- Installation.

It's therefore recommended that Inherent deviations of floor edge (structure in which the curtain wall is fixed to) be reduced to zero deflection where possible.

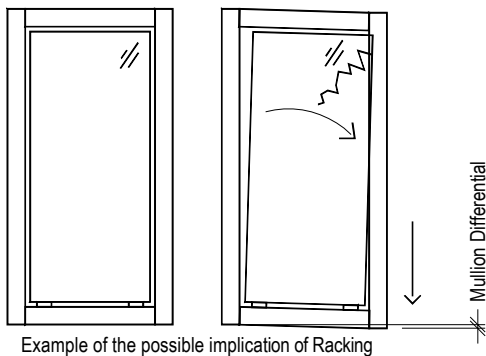

Example of the possible implication of Racking

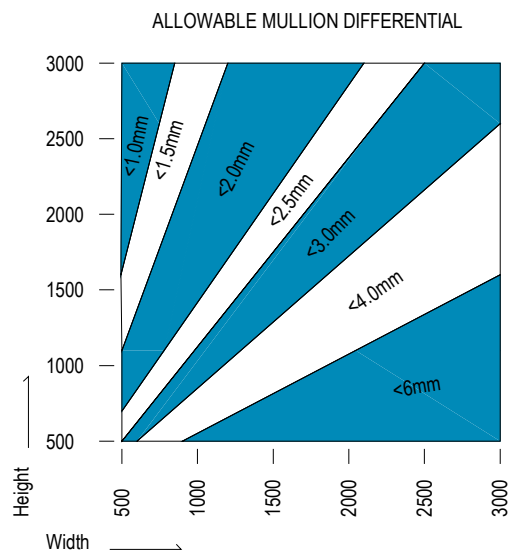

DATE: 10/03/2015	REVISION: 0	TITLE: Introduction	SYSTEM: Façade TB50 - Curtain Wall	1:1	A4	5A.01.A.10
---------------------	----------------	------------------------	---------------------------------------	-----	-----------	------------

DRAINAGE & PRESSURE EQUALIZING

Recommended set up for drainage and pressure equalizing.

Curtain Wall screen < 6M in height. (No splice joint)

Drainage path is from transom overlap into mullion and down to drainage spout 86A707 at cill level, the drain spout will push water out into the cavity between cover cap and pressure plate. Water will then exit the open end in cover cap.

Pressure equalizing is through the use of 1 drainage spout 86A707 located at the head of each mullion (install inverted). Air is taken in through the open end in cover cap and then into the mullion drainage channel through the inverted drain spout.

Insure the both ends of the cover cap are open and not blocked by any external finishes. Protect open end from water egress.

Curtain Wall screen > 6M in height. (With splice joint)

Follow all the same procedures and above (< 6M high) with and additional use of a drain spout at each floor level. (see fabrication pages for preparation on pressure plate).

(Note: Always provide a water and air tight perimeter detail around the Curtain Wall).

- ⊗ ----- AIR IN-TAKE
- ⊖ ----- WATER OUT / AIR INTAKE
- ----- WATER OUT
- ┌ ----- SPLICE JOINT

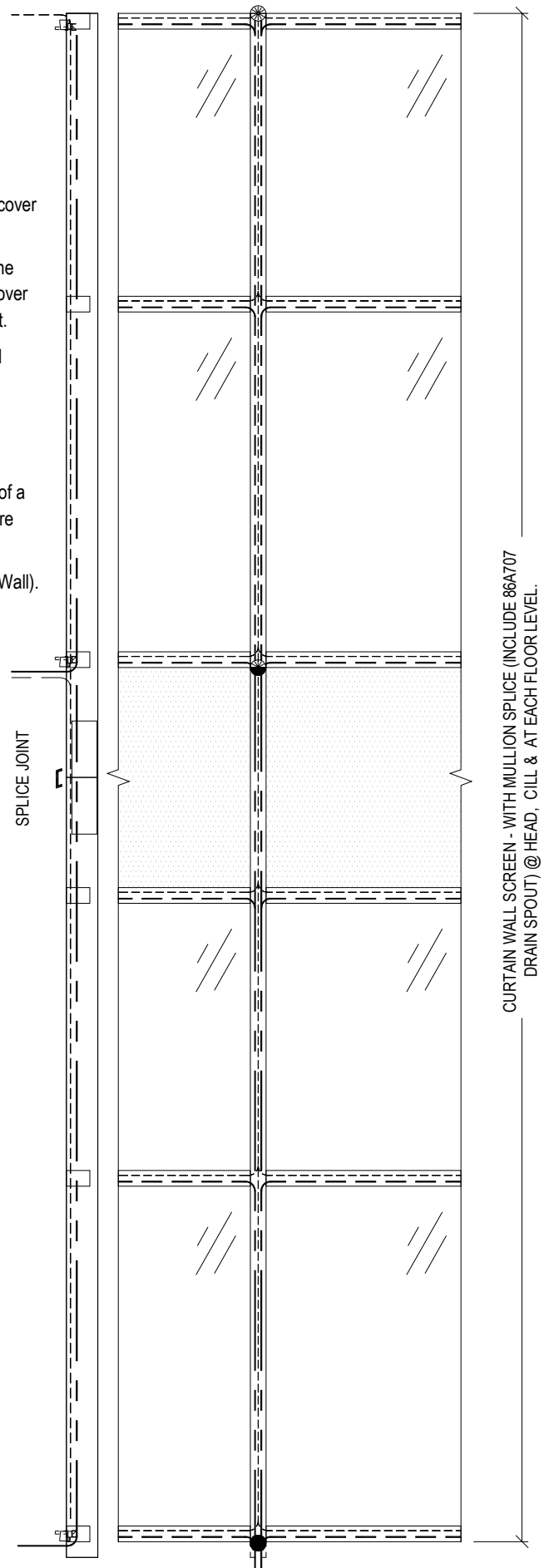
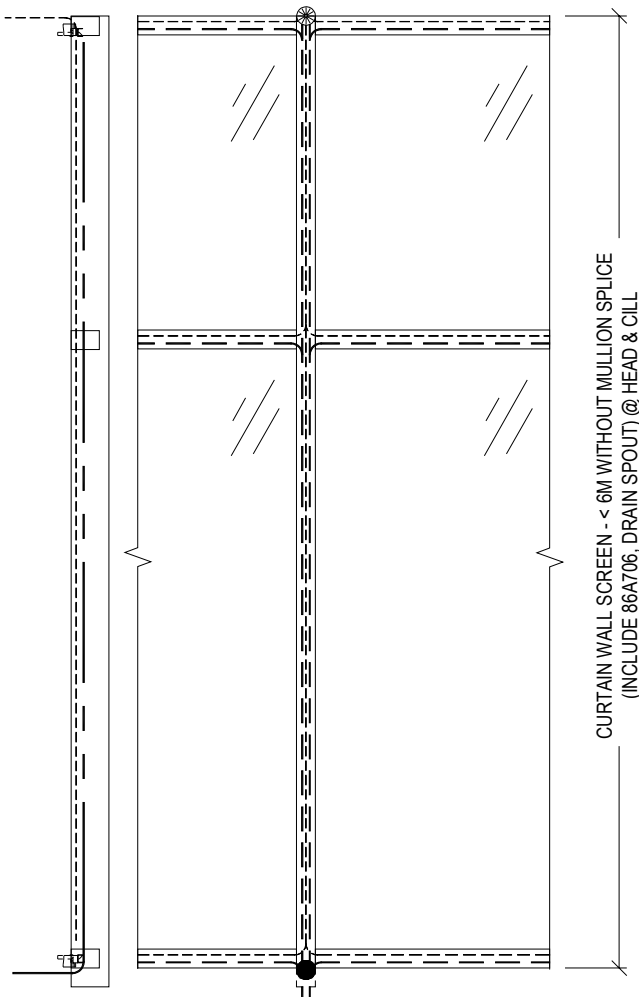

DATE: 10/03/2015	REVISION: 0	TITLE: Introduction	SYSTEM: Facade TB50 - Curtain Wall	1:1	A4	5A.01.A.11
---------------------	----------------	------------------------	---------------------------------------	-----	-----------	------------

COEFFICIENT OF HEAT TRANSMISSION FOR MULLIONS / TRANSOMS

Uf value curves are depending on the following

- Profile depth on the room side
- The depth of insert material (example glass)
- Isolator profile and material

Uf value Graph

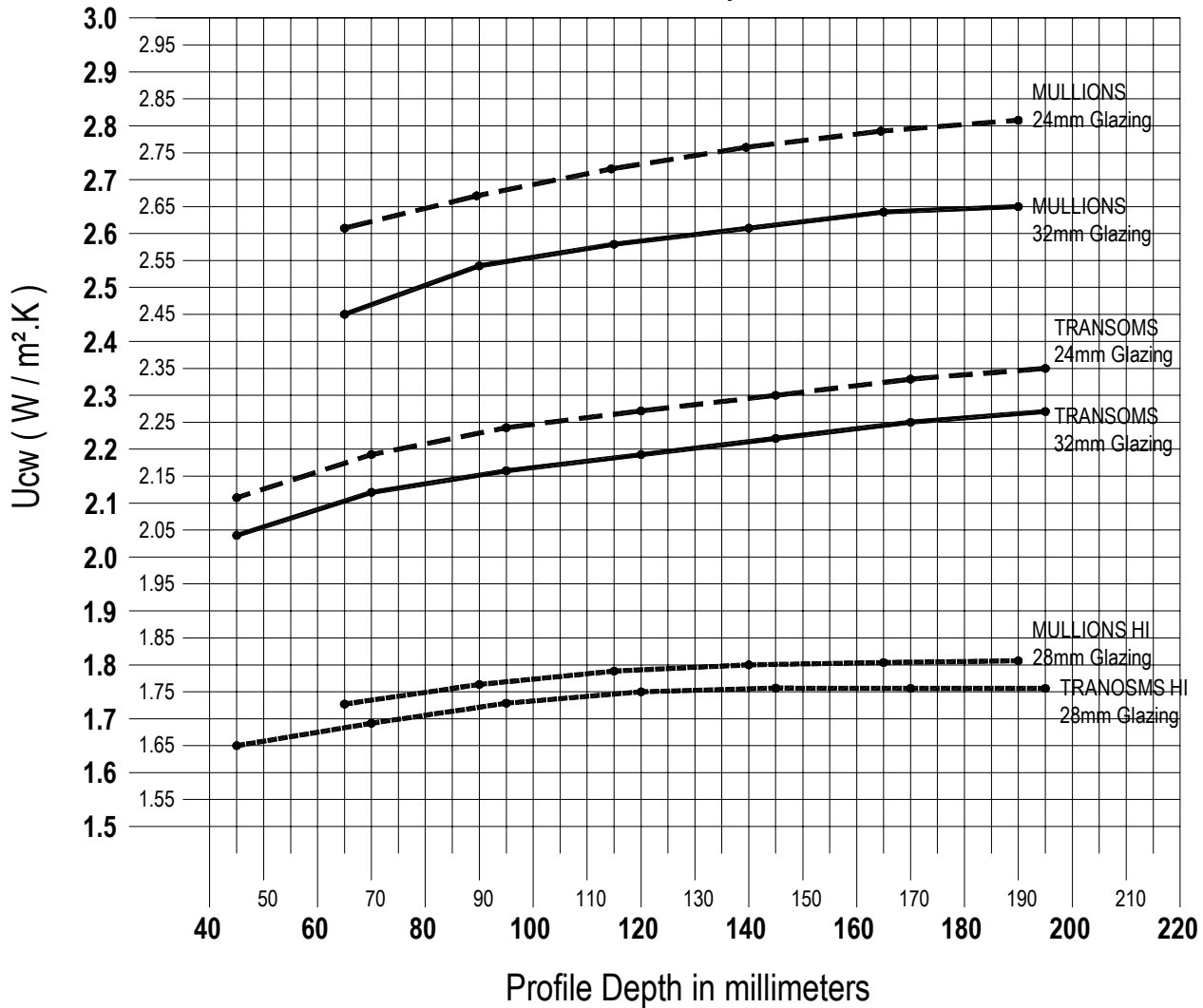

PROJECT REPORTS

The LogiKal software databases tool will provide position U-Values.

U-Value information can be given on profile combinations as you design your position. Adding your glass & panel data can then give you complete U-Value data for your positions.

DATE: 10/03/2015	REVISION: 0	TITLE: Introduction	SYSTEM: Facade TB50 - Curtain Wall	1:1	A4	5A.01.A.12
---------------------	----------------	------------------------	---------------------------------------	-----	-----------	------------